



Dual Pump Protection and Control Module

Single Phase

BIA-nXt-DPC 1-22

PN 811199

Three Phase

BIA-nXt-DPC 3-40

PN 811200

BIA-nXt DPC 3-11

PN 811201

Installation and Operation Manual



A. Shortcuts

Switching between AUTO and MANUAL:

PRESS and release the **MODE** button

Switching to Manual if the controller is in LOCK MODE:

PRESS and HOLD the **MODE** button for 5 seconds

Lock parameter # 014 in the Expert Menu Pg 13

Accumulated Run time:

Controller in manual state. Press and hold **STORE** then press **A-START**. Press **A** or **B STOP** to exit

Error log:

- Switch to MANUAL mode
- Ensure no pumps are running.
- PRESS and HOLD the **A-STOP** or **B-STOP** button, then SHORT PRESS the **MODE** button
- Press **MODE** to scroll
- Press **A-STOP** or **B-STOP** to exit

Alarm Mute:

At any time press the **A-STOP** button to mute the alarm. It will now beep every 5 minutes.

Resets after 24Hrs

Alarm Test:

Inside the controller on the display PCB is an **ALARM TEST** button



B. Shortcuts cont

Calibrating the controller to the pump

In manual mode, short press **A START** or **B START**. Allow the pump to run and the current draw to stabilise.

Once you are satisfied the pump is in its 'normal' operating range short press **STORE**. The controller should chirp.

The controller calibration value can be checked and adjusted from the User Menu
Parameter #018, 019 in the User Menu

To clear the calibration

With the pump stopped and the controller in manual mode, **PRESS and HOLD** the **A STOP** or **B STOP** for 30 seconds

USER programming menu

In manual mode, press and hold the **STORE** button for 5 sec.

Page 14

EXPERT programming menu

In manual mode, press **STORE** + then the **MODE** button. Hold for 5 seconds

Page 13

Programming:

STORE advances to the next parameter

A-START increases a value

A-STOP decreases a value

Short press **MODE** to store a value and return to the main menu

Press **STORE** for 5 sec to save changes and exit the parameter menu

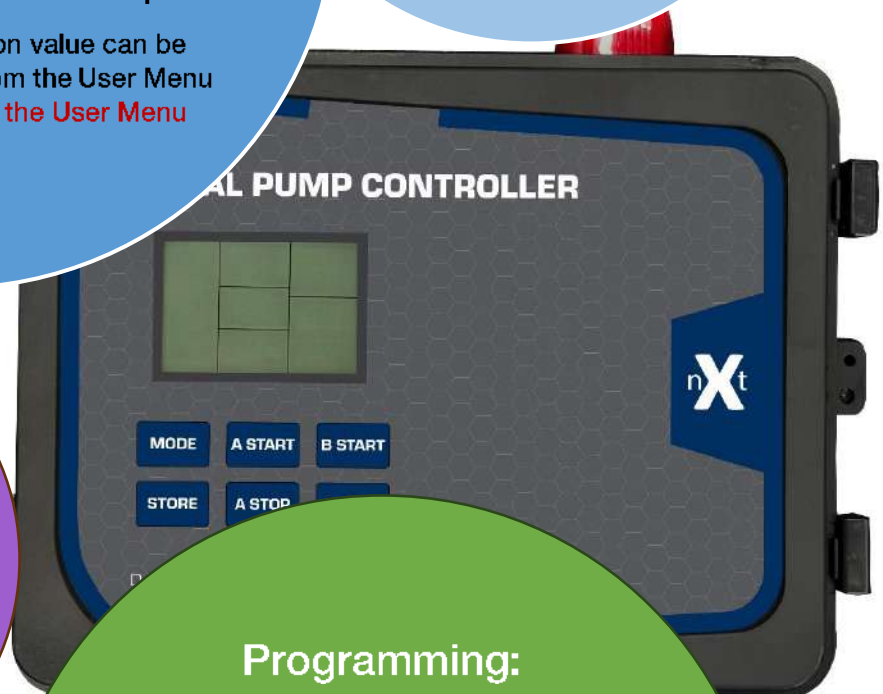

1. Introduction

Thank you for choosing a Bianco nXt-DPC (Dual Pump Control and protection module).

The Bia nXt-DPC is a module intended to control and protect dual pumps. The user can select a control logic sequence to match their application and enjoy the benefits of superior control and protection for the pumps.

There are 3 primary control logic modes:

- 'Drainage' where control is concentrated at the source
- 'Boosting' which references pressure switching on the delivery side for control
- 'Transfer' which is a mix of source and destination control







nXt-DPC has 2 x passive dry contacts and is equipped with a RS485 modbus interface to connect to a BMS

The LCD screen displays the pump running state and provides the user a wealth of useful information.

The controller is easy to set up with an initial push button calibration and individual parameters can be fine-tuned.

A nXt-DPC controller is particularly useful where there is the need to control and protect pump installations managing the automatic operation through a variety of switching methods without the need to create a bespoke control solution.





2. Warnings and Cautions

	Read the manual carefully before starting
	Prior to starting installation or maintenance the controller must be disconnected from the power supply.
	Any changes or modification to the wiring must be carried out by competent, skilled and suitably qualified personnel only.
	A qualified electrician should correctly size and install circuit breakers to protect the power supply. The fitment of additional surge protection is recommended as good practice.
	Never open the cover while controller is connected to electrical supply. Disconnect and allow the internal electronics to discharge before opening the cover
	This appliance is not intended for use by persons (including children) with reduced physical, sensory or mental capabilities, or lack of experience and knowledge, unless they have been given supervision or instruction concerning use of the appliance by a person responsible for their safety. Children should be supervised to ensure that they do not play with the appliance.
	Ensure the controller is a suitable size for the pump motor (see Section 6, Page 7: Technical Data). Size according to full load current amperage.

3. Contents

A/B. Shortcuts.....	2 - 3
1. Introduction	4
2. Warnings and Cautions.....	4
3. Contents	5
5. Modes of Operation.....	6
6. Technical Specifications.....	7
7. Display.....	8 - 8
8. Electrical Connections.....	10
9. Modbus	12
10. Parameter Calibration.....	12
11. Program Parameters.....	13
12. Quick guide: Drainage Mode, float connected to pump.....	17
13. Quick guide: Drainage Mode, floats connected to control.....	19
14. Quick guide: Transfer – source/destination control.....	20
15. Quick guide: Pressure Boosting – switched input.....	21
16. Quick guide: Drainage Mode, 4–20mA level transmitter.....	23
17. Quick guide: Transfer – source/destination control 4-20mA	24
18. Quick guide: Pressure Boosting 4-20mA	25
19. Backup power supply.....	26
20. Fault Messages.....	27
21. Accessories.....	28
22. Warranties – Terms and Conditions.....	29

4. ISO 7010 Symbols used in this manual

	Warning - Electrical safety
	Warning – Potential consequences of use outside of intended application(s). Includes environmental condition warnings.
	Mandatory warning
	Warning to disconnect power
	Read carefully

5. Modes of Operation

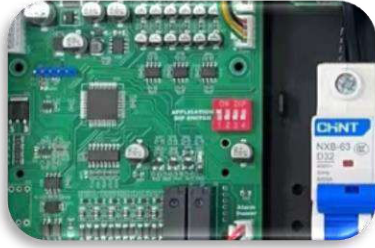

On the main PCB there is a 4 position 'Dip Switch'

To alter the control logic to suit an application, the installer must select the appropriate switch position.

After selecting the desired switch position, **cycle the controller power to apply the setting.**

Binary	Switch position	Control logic - Applications
000		'Drainage' Mode where the control inputs (generally level floats or probes) are located at the source. (default)
010		'Drainage' Mode where the level control input is managed by a flexible float on the pump.
111		'Pressure Boosting' Mode. Main control via (N/C) pressure switch. Supports run / no run level protection at the source via floats or probes.
101		'Transfer' Mode. Main control via control inputs (floats or probes) at destination or by a pressure switch on the delivery line. Supports run / no run level protection at the source.
0*		OTA/OTB terminal enabled (default)
1*		Enables the connection of a PT00 temperature sensor (i.e. pump over-temp sensor) A separate PT100 temperature sensor expansion module is required
011*		'Drainage' Mode with overflow alarm through a 4-20mA level transmitter.
001*		'Pressure Boosting' Mode controlled via a 4-20mA pressure transmitter. Supports run / no run level protection at the source via floats or probes.
100*		'Transfer Mode' with 4-20mA level transmitter at the destination. Supports run / no run level protection at the sources via floats or probes.

When first powered on the nXt-DPC will display the current dipswitch operating mode (binary code), the hardware and the software version.



6. Technical Specifications

Controller Modes	Automatic or Manual pump operation. Liquid level control via float switch, electrode probes OR 4-20mA level transducer. Pressure control via pressure switch or 4-20mA transducer
Protection functions: <i>(Three phase only:</i>	Dry run (Underload), Overload, Pump Stalled, Transient surge, Under voltage, Over voltage, Phase reversal, Phase Imbalance) Open phase protection Repeated start, Short circuit, Over temperature <i>Over temperature requires an optional relay</i>
Input Voltage	Single Phase: 230V +10% -6% Three Phase: 415V +10% -6%
Rated output power Per pump	DPC 1-22 nominal 0.37 to 4 kW P2 power (max 12A input) DPC 3-40 nominal 0.37 to 4 kW P2 power (max 12A input) DPC 3-11 nominal 2.2 to 11 kW P2 power (max 25A input)
Minimum working current Per pump	DPC 1-22 = 1 amp DPC 3-40 = 1 amp DPC 3-11 = 5 amp
Working temp	-25 to +55 deg C 20% to 90% relative humidity, non-condensing
Controller size	342mm wide, 253mm tall, 130 deep. IP54
Trip response times (set)	Open phase – Less than 2 sec Short circuit – less than 0.1 sec
Trip Voltage (User adjustable)	Over voltage: Default = 276V Default = 437V Under voltage: Default = 192V Default = 304V
Trip response times (User adjustable)	Dry run (Under-load) 5 sec Under Voltage Less than 5 sec Over voltage Less than 5 sec
Recovery times (User adjustable)	Dry run (Under-load) 45 min default Overload 4 min default Under Voltage 4 min default Over voltage 4 min default
RS485 Technical interface	RS485 Bus Interface: asynchronous semi duplex 1200,2400,4800,9600 bps (default 9600bps) MODBUS protocol (RTU)
Alarms	Visual and audible alarm. Supports external alarm connection



To avoid 'nuisance' alarming, many of the default protection parameters have values with a wide tolerance. The installer is encouraged to optimise the settings to achieve optimum results

7. Display

The DPC display provides a real time indication of the operational mode and the current state of the controller, including real-time voltage/current and any error messages.

Only the icons relevant to the selected operational mode will display.

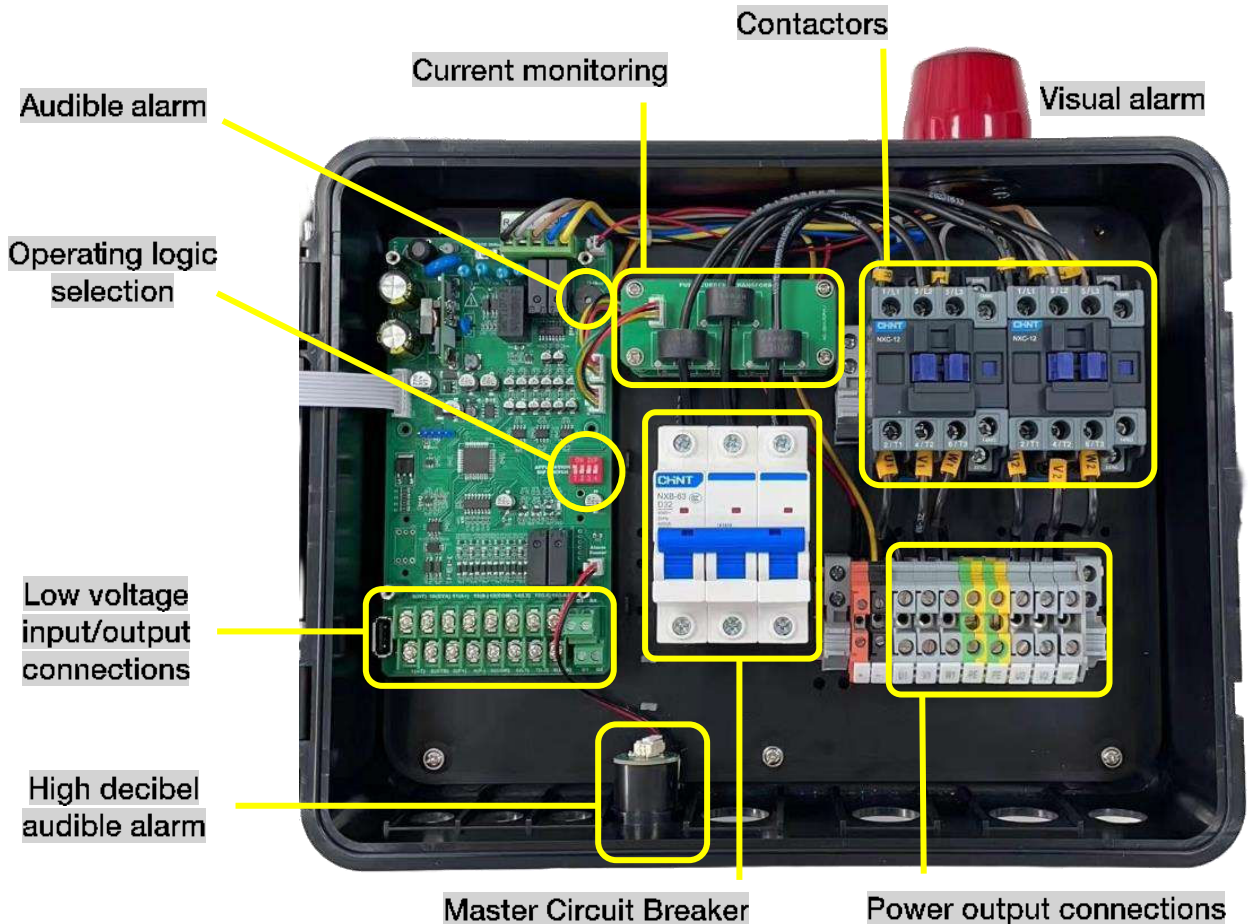
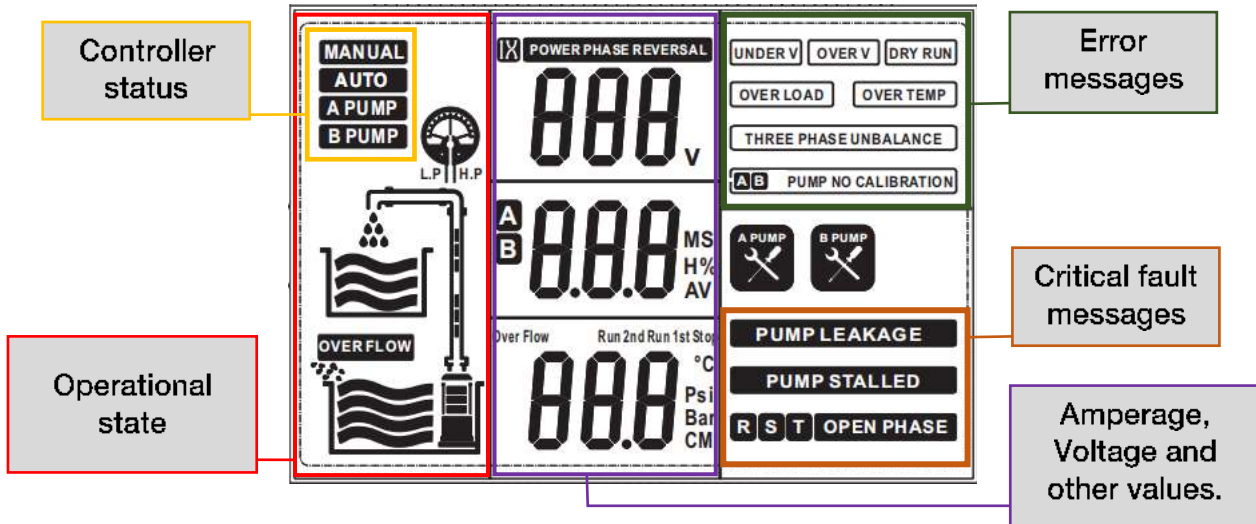





7. Display con't

The nXt-DPC controller operates according to the pre-programmed logic for each 'mode'.

Changing the Dip Switches inside the controller then **cycling the power** will activate the selected logic mode.

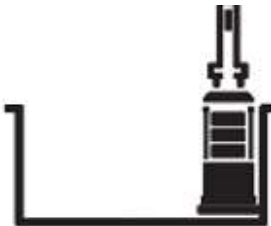
Examples of common applications are detailed later in this manual but with an understanding of how the controller responds to various inputs in each of the modes the controller can be used for application other than what is suggested.

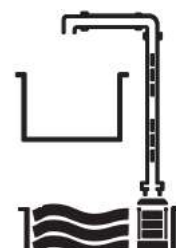
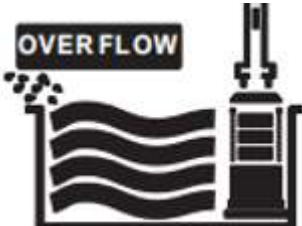
The appearance of the front display changes according to each mode and provides a visual indication to the state of the input signals.

	Lack of source water		High pressure Low pressure
	Source water full		Destination low
	Overflow		Destination full

Avoid installing the nXt-DPC where it could experience the following conditions:

- i. Where there is significant vibration and/or mechanical shock.
- ii. Where it could be exposed to corrosive liquids or gasses, or to flammable materials, solvents etc.
- iii. Extreme heat and cold. Operating range -25°C - 55°C.
- iv. Protect the controller from rain, moisture, humidity or dust

8. Electrical Connections

Always use an electrical outlet that is protected by Residual Current Device (RCD) Safety Switch with a trip current of 30mA or less. A Safety switch is required by Australian/New Zealand Standard AU/NZS 60335.1-2011.



All high voltage wiring must be connected by a suitably qualified technician.

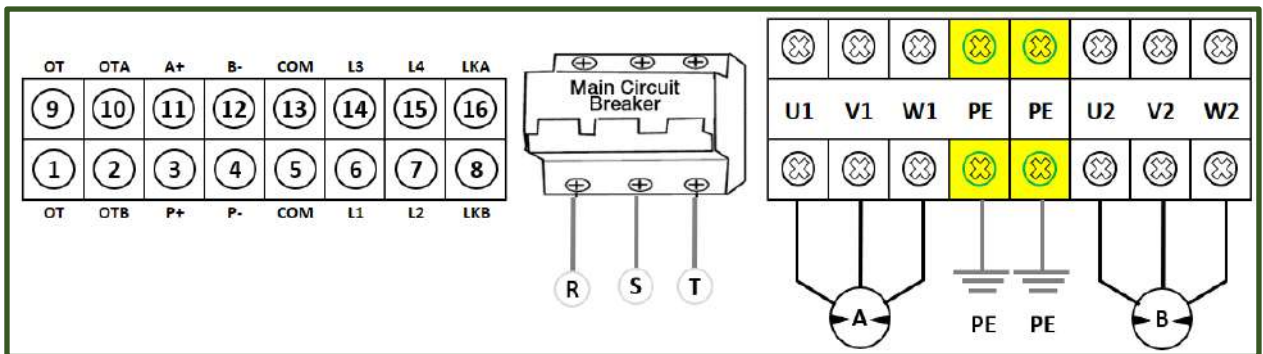
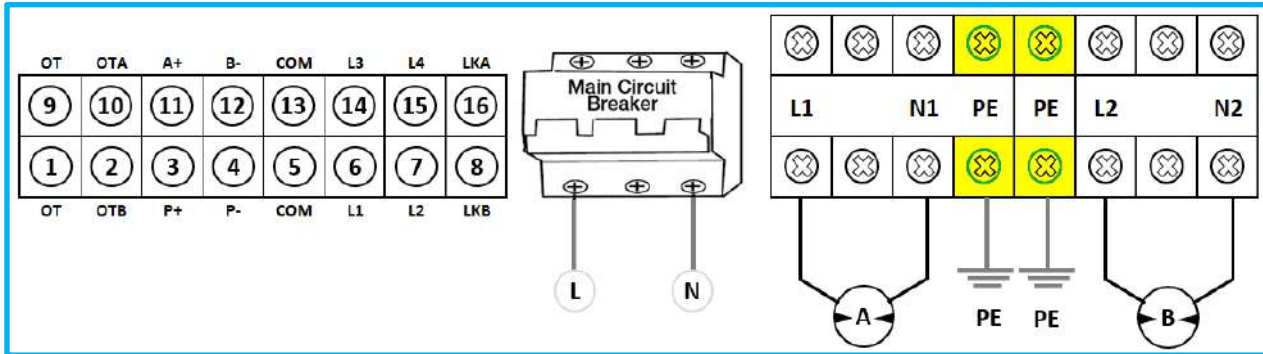

It is the responsibility of the installing electrical technician to ensure that the cable cross section (mm²) meets the requirements of AS/NZS 3008; taking into consideration the cable type, the cable length, the current draw and other relevant factors.

If in doubt online resources exist i.e. Cable Size Calculator AS/NZS 3008 or seek advice from an electrical engineer or other suitably qualified person(s)

Output Terminals



The nXt DPC has two 'Dry Contact' terminals.

D1, D2 activate in the event of a critical fault

D3, D4 activate briefly whenever the controller is changed between its Automatic and Manual state (which requires physical intervention)



8. Electrical Connections cont

Pump over temperature protection sensor wiring terminal

Terminal	Definition
9(OT) + 10(OTA) See Pg 6. Dip switch to 0*	Pump over-temp protection sensor. Set to 0* is a N/O circuit, bridged unless connected. Standard thermals will open to peak signal and stop pump on overheat
9(OT) + 10(OTA) See Pg 6. Dip switch to 1*	PT100 connection. Set to 1* the circuit looks for the variable signal from a PT100 sub-board

Pump moisture protection sensor wiring terminal

Terminal	Definition
13(COM)+16(LKA)+8(LKB)	Pump leakage protection sensor

Dry contact (passive contact) point wiring terminal

Terminal	Definition
D1 + D2	Dry contact point for pump failure indication N/O circuit. Activates when there is a critical fault
D3 + D4	Dry contact for auto/manual status indication N/C circuit

4-20mA transmitter wiring – Modes 011 Drainage, 001 Boosting and 100 Transfer

Terminal	Definition
3(P+) + 4(P-)	4-20mA level/pressure transmitter

RS485 communication terminal

Terminal	Definition
11(A+) + 12(B-)	RS 485

Full factory reset

- Turn off power to the control panel,
- Press and hold the **A-STOP** button and reapply power
- When the display shows 099, release the **A-STOP** button.

9. Modbus

Main technical data	
Physical interface	RS485 Bus Interface: asynchronous semi duplex
Data format	1 start bit, 8 data bit, 1 stop bit, no verify 1 start bit, 8 data bit, 2 stop bit, no verify Default: 1 start bit, 8 data bit, 1 stop bit, no verify
Baud rate	1200,2400,4800,9600 bps (default 9600bps)
Communication address	Setting range of controller address: 1-126. 127: broadcast address, host computer broadcasting, slave machine response forbidden
Protocol type	MODBUS protocol (RTU)
Rated input voltage for SC	AC 240V/50Hz, single phase
Main installation data	
Wire communication distance	1200 m max by shield twisted pair cable (STP)for RS485 & CAN 5000 m max by STP and RS485 extender
STP	STP-120U one pair 20AWG for RS485 & CAN

10. Parameter Calibration



The pumps must be able to pump water to enable correct calibration. Calibrated without water, overload and pump stalled errors may occur later. Calibration can be performed automatically as explained on Page 3 OR by accessing the User parameter menu #018, 019 and manually inputting the desired values

When a new pump is installed, or an existing pump reinstalled after maintenance, erase the former calibration and a perform a fresh calibration.



To access parameter settings the controller should be in **Manual Mode** and the pump(s) should NOT be running.

User Menu – Press the **STORE** button

Expert Menu – Press the **STORE** and **MODE** buttons for **5 seconds**

To enter a parameter, press the **STORE** button to advance to the next parameter and display the current value.

To change the value, press the **A-START** to increase or **A-STOP** to decrease.

To store all changes and exit the parameter menu hold the **MODE** button for **5 sec**

11. Program Parameters

Controller unlocked

Press  to switch between AUTO and MANUAL mode

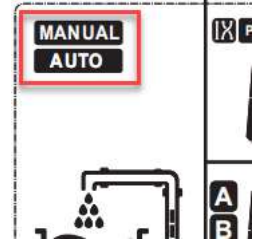



Controller locked (Parameter 014 active)

Press and hold  to switch to MANUAL mode

The controller operating mode will be displayed in the top left corner of the display

EXPERT MENU – Parameters 001 - 017

ITEM	DEFAULT	OPERATION
001	3 sec	Pump stall delay time before applying protection To make provision for inrush current on pump start. Range 0 - 60
002	OFF	Repeated start protection. Options ON/OFF
003	ON	Over-temp protection. Related to terminal connection 9 and 10. Dip switch #4 in the up position
004	OFF ON	Phase Reversal Protection - not applicable to single phase model When using the nXt DPC in conjunction with a VFD set to OFF
005	OFF ON	Open Phase Protection
006	ON	Pump enable / disable function <ul style="list-style-type: none"> • B pump enabled, A Pump Disabled • Both pumps A pump and B pump enabled • A pump enabled, B Pump Disabled <p>An indicator on the left hand side of the screen shows which pump(s) are enabled. Disabled pump(s) are indicated by  icon(s) on the RHS</p>
007	AUTO	Auto and Manual function setting <ul style="list-style-type: none"> • Both Pumps automatic operation • A Pump Automatic operation, B Pump Manual operation • B Pump Automatic operation, A Pump Manual operation <p>An indicator on the left hand side of the screen shows which pump(s) are in automatic mode. Pump(s) in manual mode are indicated by the  icon(s) on the RHS</p>
008	OFF	Pump Alternation: The continuous running time after which the operating pump will switch over. Not related to start alternation Range Off – 254 min

11a.Program Parameters cont

009	96 hour	Anti Seize Protection: Cycle time. Range: Off or 1 – 254 hr
010	OFF	Boosting mode only - Start delay time Range: Off or 1 – 254 sec
011	OFF	Boosting mode only - Stop delay time Range: Off or 1 – 254 sec
012	OFF	Boosting mode only - Maximum run time Off or 1 – 254 min
013	OFF	Fault Alarm audio setting When a fault occurs and activates the alarm, after the time specified in parameter #013 & #016 the continuous alarm will switch to chirp mode (lasts 1sec) at 5-minute intervals. Range: 00 – 24 hrs
014	OFF	Button lock function Off / On
015	01	Controller ID 00 – 254
016	04	RS485 Speed 01 =1200, 02 = 2400,03 = 4800, 04 =9600 bps (default 9600bps)
017	00	Parity check 00 = None 01 = Odd parity 02 = Even parity

USER MENU – Parameters 018 - 034

ITEM	DEFAULT	OPERATION
018	25A	Rated output. Pump calibration value Pump A
019	25A	Rated output. Pump calibration value Pump B
020	75%	Trip response ratio – Dry run (underload) protection Range: Off – 95%
021	130%	Trip response ratio – Over-load protection Range: Off – 170%
022	180%	Trip response ratio – Pump stalled / locked rotor protection Range: Off – 195%
023	20%	Trip response ratio – Phase imbalance 3 phase only Single phase, default is off Range: Off – 50%
024	192V 332V	Trip voltage – Under Voltage Protection
025	276V 477V	Trip voltage – Over Voltage Protection

11b. Program Parameters cont

026	5 sec	Trip response time – Dry run Protection Range 1 – 60 sec
027	45 min	Recovery time – Dry run Protection Range 1 – 254 min
028	4 min	Recovery time – Overload protection Range 1 – 60 min
029	4 min	Recovery time – Under/Over Voltage, Phase Imbalance Range 00 – 60 min
4-20mA Input Mode 011 / 001 / 100 See Section 5 – Modes of Operation		
030	Mode Dependant	Level Sensor range Drainage/Transfer 0-200cm, Boosting 0 – 25 bar
031	Mode Dependant	Pump stop setting
032	Mode Dependant	Start pump setting
033	Mode Dependant	Second pump cut in setting
034	Mode Dependant	Overflow/Over pressure setting

If a replacement pump is installed, the previous calibration should be removed and a new calibration performed.



nXt-DPC Pro controllers offer a cost-effective and dependable solution for enhancing pump control and protection, eliminating the need for expensive customized switchboards.

On the following pages you'll find guides outlining typical applications. Once you grasp how the controller reacts to inputs across its modes, you'll discover its potential for applications beyond the standard suggestions.

For instance, you can integrate the controller in line with a VFD pump controller to introduce additional control inputs or capitalize on the nXt-DPC controller's delay capabilities.

For heightened flexibility in your setup, consider employing the nXt-DPC controller as a modular component within a more intricate control system. For even greater flexibility in your installation the nXt-DPC controller can be used as a 'module' in a more complex control environment.

Float wiring

Source control - Single float

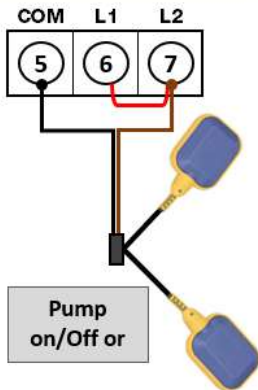

3 wire' floats allow for Normally Open or Normally Closed wiring.

Connecting to the controller using the black and brown wires, the circuit is closed when the float is up, open circuit when the float is down.

For greater differential, dual floats can be attached on the source inputs 5, 6 and 7.

When using a single float on the source input terminals #6 and #7 need to be bridged

Source control - dual float

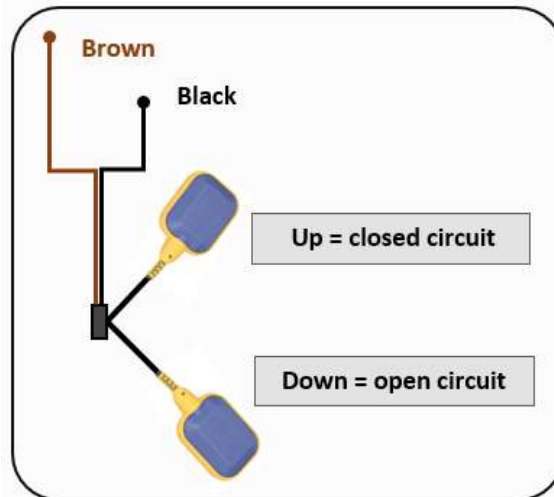
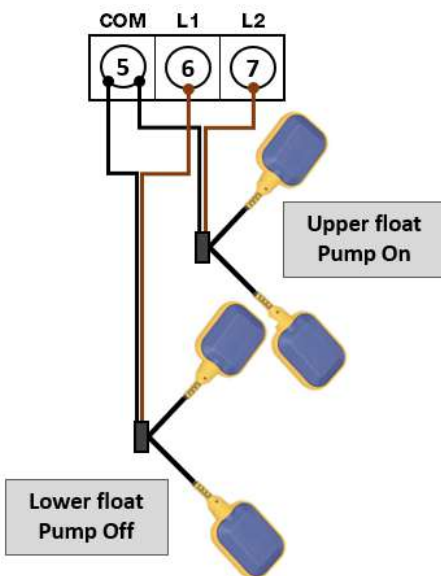

Pressure switches

Standard pressure switches used in pump application are closed circuit at low pressure and open circuit at high pressure.

Reverse acting pressure switches are also available – open circuit at low pressure and closed circuit at high pressure.

Ensure the pressure switch type employed is correct for the mode logic selected.

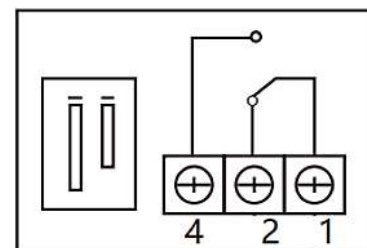

12. Quick guide: Drainage Mode, float connected to pump



Set the dip switches on the main PCB and cycle the master circuit breaker

Set to this operational mode, effectively there is power supplied to the pump continuously. The stop/start function is controlled by the float connected to each pump. In this mode, the pumps will not alternate nor is underload (dry run) protection possible.

Pump On/Off operation is controlled by the float fitted to each pump.

The Controller provides additional protections including dry run, start/stop delay times and pump start alternation.

A float connected to the controller can provide high level alarm function.

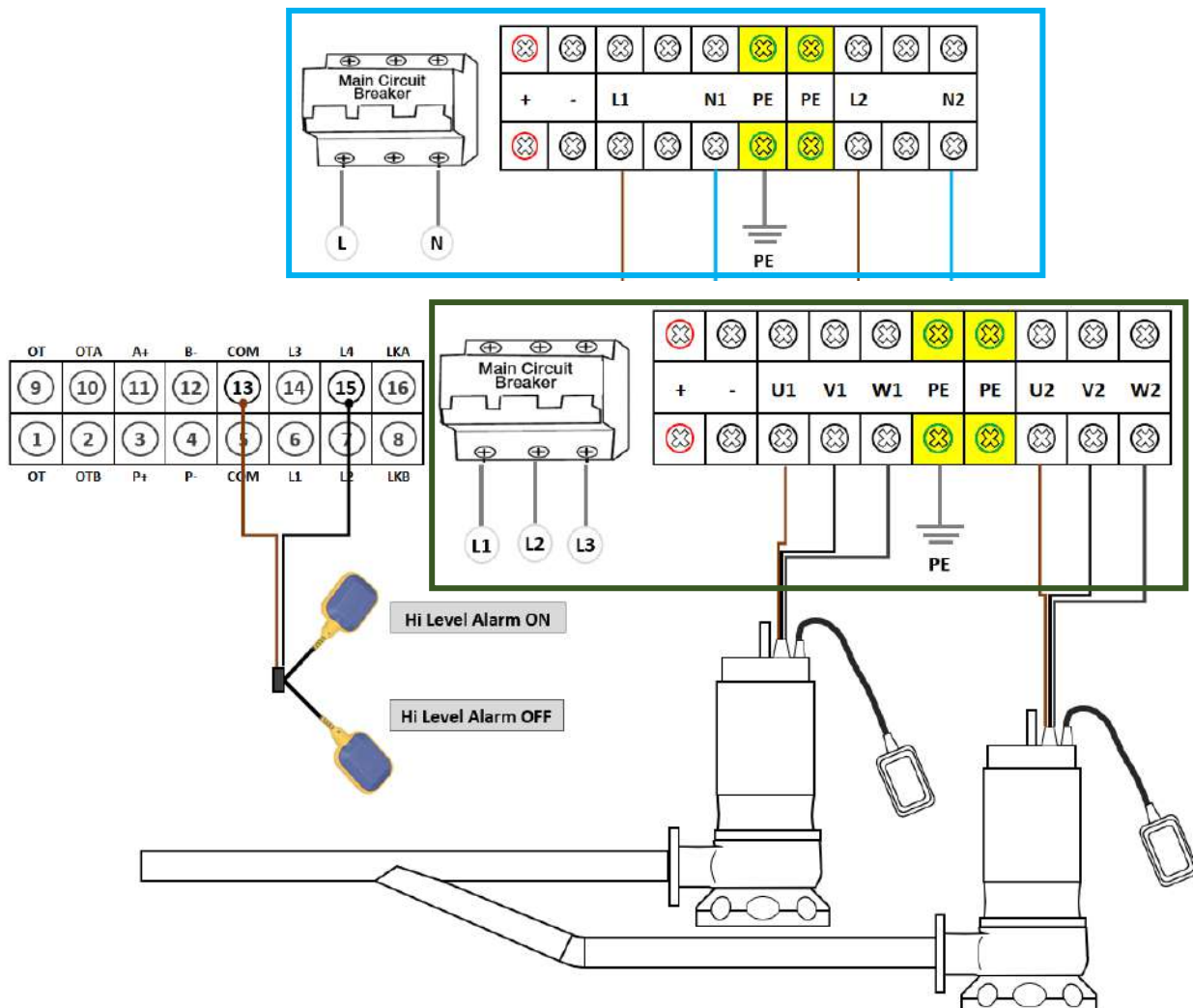

12a. Quick guide: Drainage Mode, float connected to pump

Auto Mode

- I. In this mode. L1, L2 and L3 effectively have no function.
- II. The controller provides power to a pump (Active pump selection alternates)
 - The first pump will run until its float switch turns it off and the current draw falls to zero.
 - At this point the controller will switch and supply power to the second pump.
 - When the pump float is in a run state, the 2nd pump will operate.
- III. COM + L4 in a Closed state triggers the Audible and Visual Alarm AND supplies power to both pumps.

Both pumps and the alarm will operate until COM + L4 returns to an Open state (at which point the alarm ceases)

Both pumps continue to run until their individual floats Stop the pumps running

Note: For the controller to switch to the second pump, the PLC must first register current draw greater than zero, and then a return to zero. In the event of a pump failure, the second pump may not operate until triggered by the COM+ L4 circuit closing.

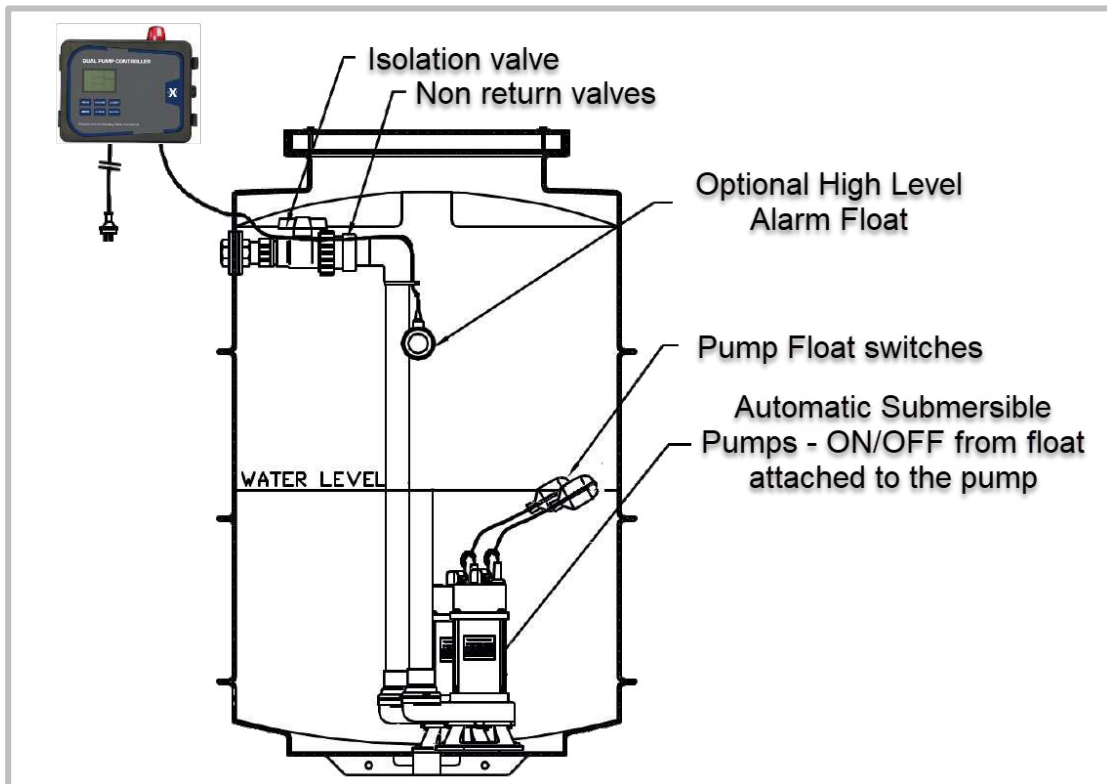

13. Quick guide: Drainage Mode, floats connected to control

This is the default mode as supplied



Set the dip switches on the main PCB and cycle the master circuit breaker

A pump with its own float can be used in this configuration so long as the operational level of **Pump Stop Switch #1** is HIGHER than the float attached the pump.

Switched input - bridge terminals 6 (L1) and 7 (L2).

First pump switches on when the Lower float switch reaches its On (Up) position

Pump will run until the Lower float switch returns to its Off (Down) position

If the liquid level continues to climb and the Upper float switch reaches its On (Up) position the second pump will start. It will run until the Lower float switch returns to its Off (Down) position.

The High-Level alarm triggers when the High-Level alarm float switch reaches its On (Up) position.

The alarm will turn off when the High-Level alarm switch returns to the Off (Down) position.

Both pumps continue to run until the Lower Pump float switch is in the Off (Down) position.

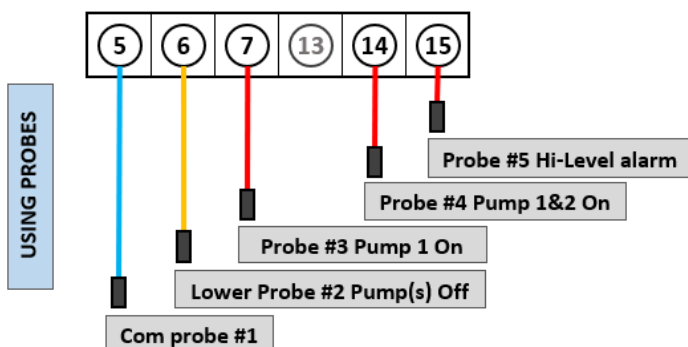
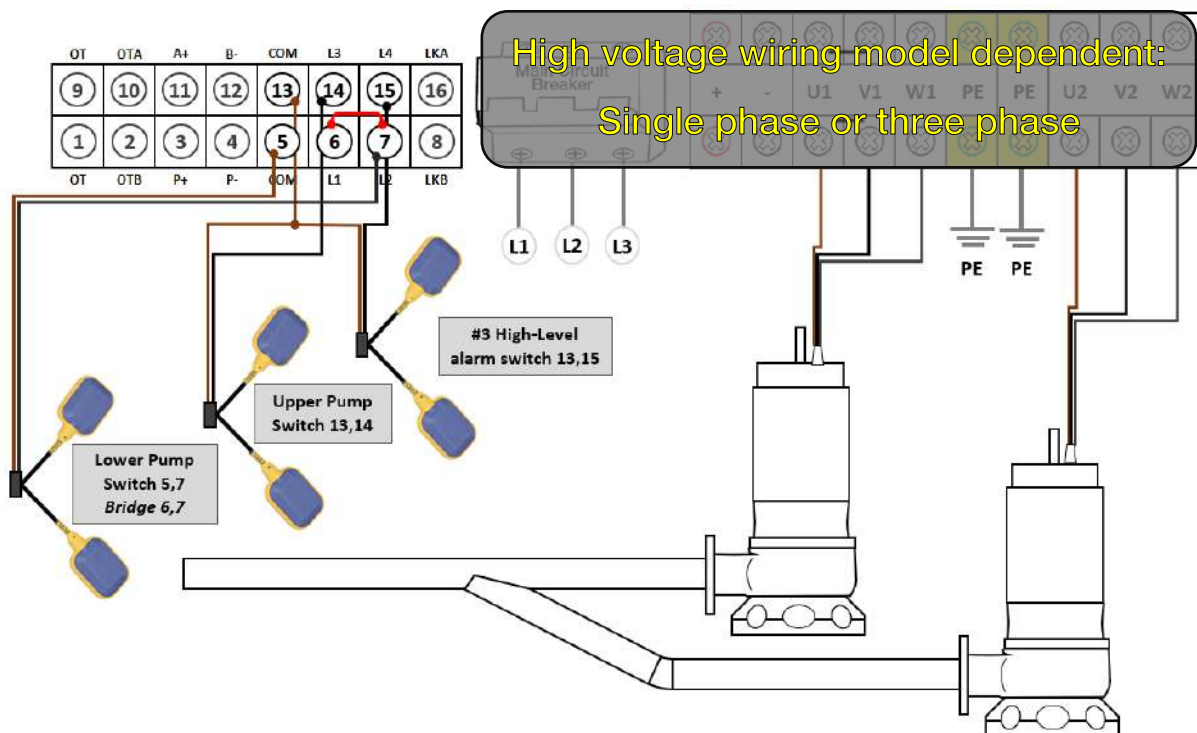

The controller alternates whichever pump starts first every startup cycle.

Should the first pump shut down due to an alarm condition, the controller will automatically transfer duty to the second pump.

14. Quick guide: Transfer – source/destination control



Set the dip switches on the main PCB and cycle the master circuit breaker

Switched input:

Bridge terminals 14 (L3) and 15 (L4)

Pump On/Off operation is requested by the floats at the destination.

A float switch or probes at the source controls whether the pump will run or not depending on the liquid level.

Should the level continue to drop despite a single pump running, the second pump will start when the level falls to the L2 (#7) position

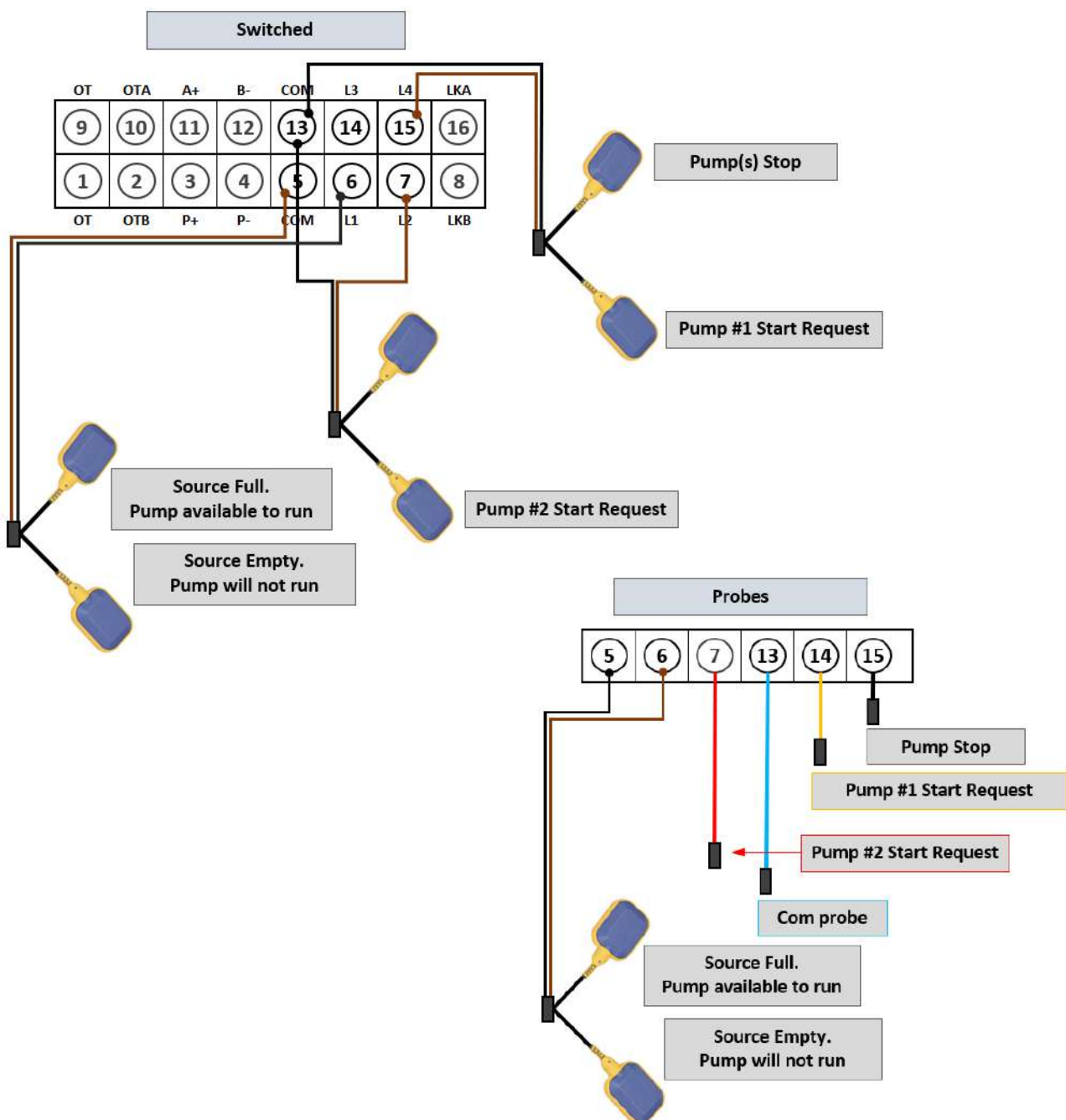

15. Quick guide: Pressure Boosting – switched input



Set the dip switches on the main PCB and cycle the master circuit breaker

Switched input

Pump On/Off operation is controlled via pressure switches on the delivery line. Additional (optional) run/no run protection can be fitted at the source

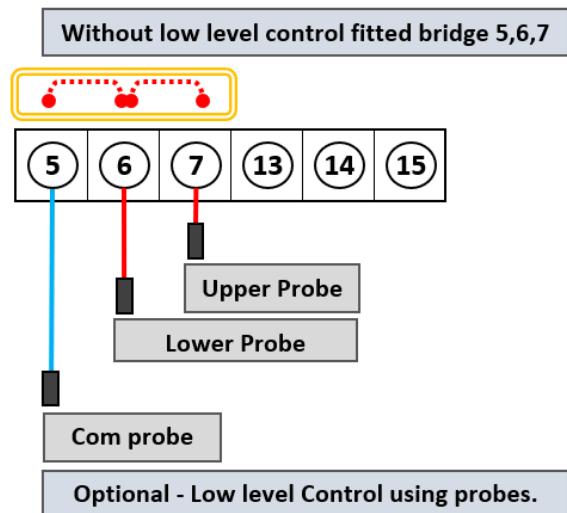
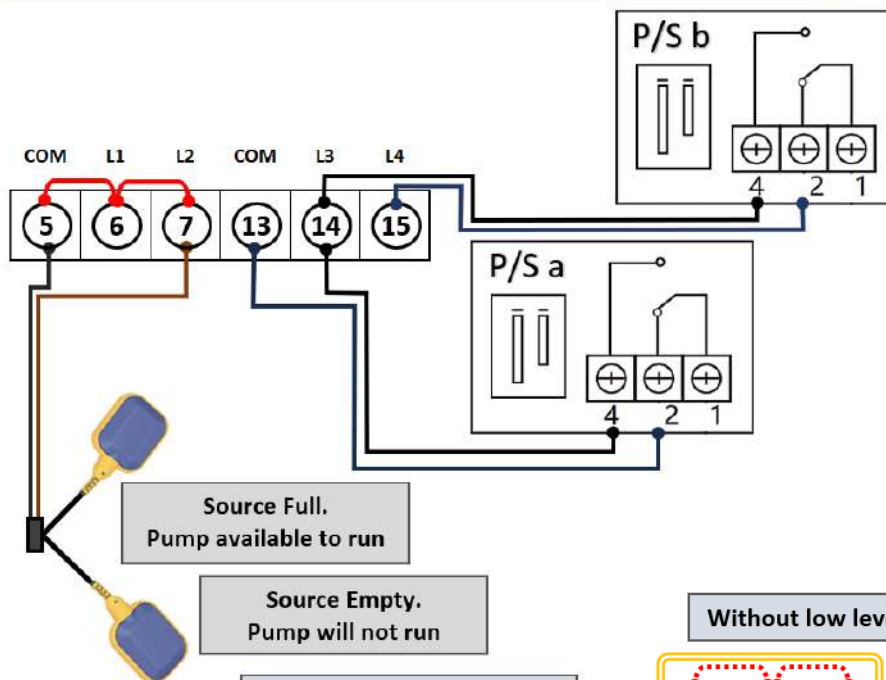
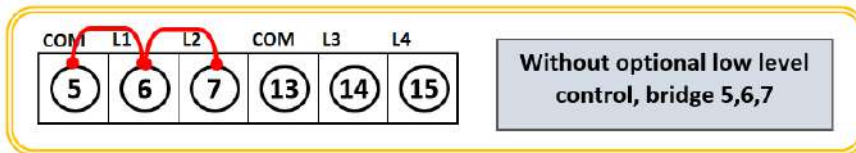

When the controller is set to Boosting Mode, Parameters 005 – 007 become available and can be employed to provide additional control.

- Start delay time **Parameter 010** – Default Off
- Stop delay time: **Parameter 011** – Default Off
- Maximum run time: **Parameter 012** – Default Off



When using pumps of dissimilar performance i.e. a jockey and a primary pump, ensure **Parameter 008 = 0** (Never alternate)

Selecting the Cut in and Cut out pressures for 2 identical pumps:

1. Pump A (Duty pump) Set the Cut-Out pressure. Ensure set point doesn't exceed the pump maximum head.
2. Pump B (Assist pump) Set the Cut-In Pressure toward the lower end of the Duty pump performance. Ensure there is no risk of Duty pump cavitation.
3. Set the Pump A (Duty pump) Cut-In and the Pump B (Assist pump) Cut-Out halfway between the maximum and minimum settings.

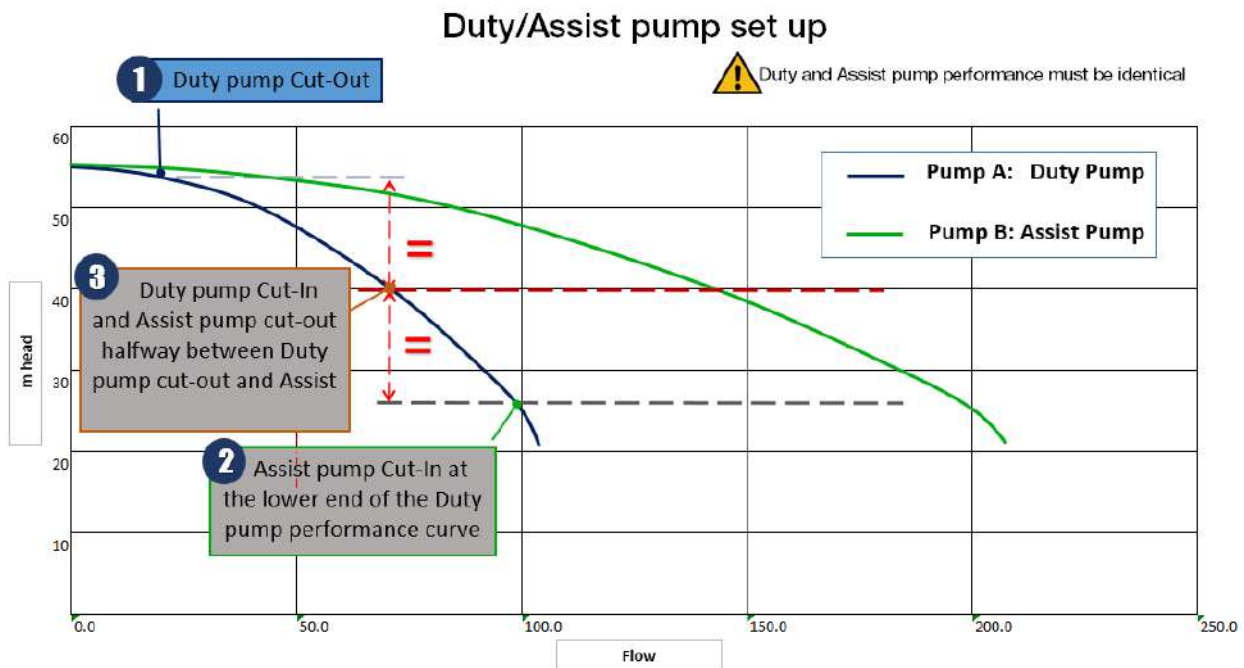

In this example Pump A (Duty pump) will start when the system pressure drops below 4.0 bar.

If Pump A (Duty pump) cannot keep up with the demand flow and pressure drops to below 2.5 bar, Pump B (Assist pump) will start.

As demand flow reduces, the system pressure will increase. Pump B (Assist pump) will switch off when system pressure reaches 4.0 bar leaving Pump A (Duty pump) to supply demand.

When demand flow further decreases Pump A will turn off when system pressure reaches 5.5 bar.



A suitably sized pressure vessel should be incorporated in the system to ensure pump starts don't exceed 20 starts/hour OR the manufacturers recommendation.

16. Quick guide: Drainage Mode, 4-20mA level transmitter



Set the dip switches on the main PCB and cycle the master circuit breaker

Pumps with their own float can be used in this configuration so long as the Parameter 032 is HIGHER than the level at which the pump float switches the pump off

4-20mA input.



Transmitter accuracy is a percentage of the sensor full range. Choose the 4-20mA level transmitter with a measuring range according to depth of source tank.

The installer must enter the correct values for 5 parameter settings

- | | |
|--|---------------|
| 1) Level transmitter full measuring range | Parameter 030 |
| 2) Overflow alarm liquid level depth value | Parameter 034 |
| 3) Pump 1 cut-in/start liquid level | Parameter 032 |
| 4) Pump 2 cut-in/start liquid level | Parameter 033 |
| 5) Pump(s) cut off liquid level | Parameter 031 |

Set to drainage mode, parameters 030 to 034 are in centimetres (cm)
These are the control levels related to the source

Example:	Full measuring range:	200cm
	Overflow alarm depth value:	150cm
	Pump 1 cut-in (start) depth:	60cm
	Pump 2 cut-in (start) depth:	100cm
	Pump(s) cut-out (stop) depth:	20cm



Ensure the sensor is at least 50mm above the bottom of the sump

17. Quick guide: Transfer – source/destination control 4-20mA



Set the dip switches on the main PCB and cycle the master circuit breaker

4-20mA input.



Transmitter accuracy is a percentage of the sensor full range. Choose the 4-20mA level transmitter with a measuring range according to depth of source tank.

The installer must enter the correct values for 5 parameters

- | | |
|---|---------------|
| 1) Level transmitter full measuring range | Parameter 030 |
| 2) Overflow alarm liquid level depth | Parameter 034 |
| 3) Pump 1 cut-in liquid level | Parameter 032 |
| 4) Pump 1 cut-in liquid level | Parameter 033 |
| 5) Pump cut off liquid level | Parameter 031 |

Set to Transfer mode, parameters 030 to 034 are in centimetres (cm)
These are the control levels related to the destination

Example:	Full measuring range:	200cm
	Overflow alarm depth:	150cm
	Pump 1 cut-in (start):	100cm
	Pump 2 cut-in (start):	130cm
	Pumps cut-out (stop):	20cm

The destination control (transducer) provides a request to start based on liquid level. The Source level control allows the pump to start only if there is sufficient liquid to have the source float in the up position

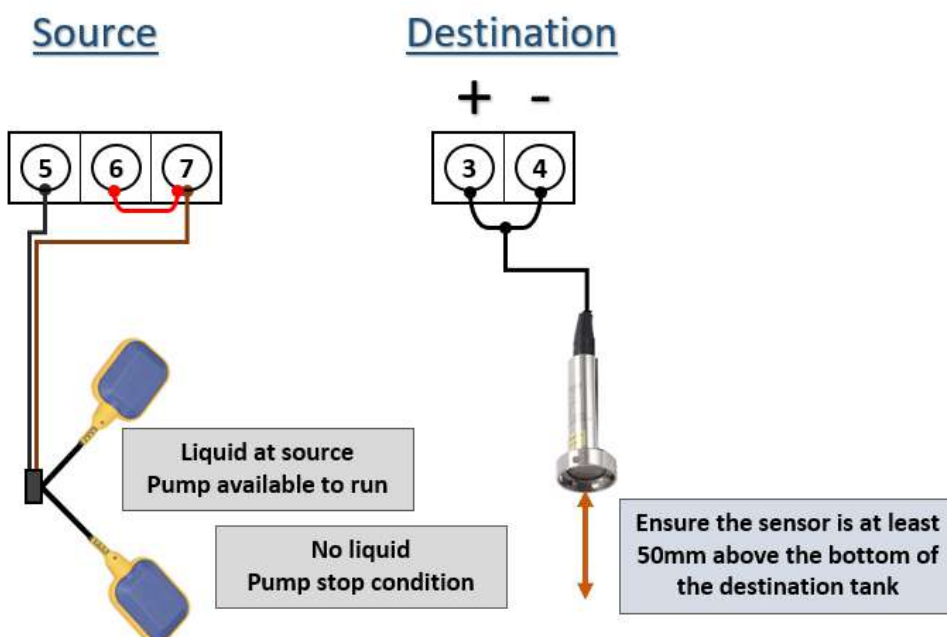

18. Quick guide: Pressure Boosting 4-20mA



Set the dip switches on the main PCB and cycle the master circuit breaker

4-20mA Pressure transducer:

Pump On/Off operation is controlled via a 4-20mA transducer on the delivery line.

Additional (optional) run/no run protection can be fitted at the source

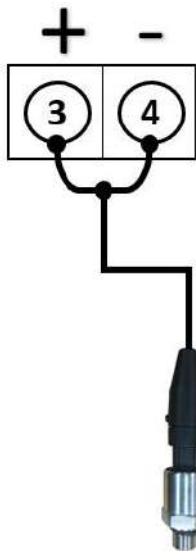

Fitted to delivery line

- | | |
|---|---------------|
| 1) Pressure transmitter full measuring range in bar | Parameter 030 |
| 2) Over pressure alarm value | Parameter 034 |
| 3) Pump cut-off (stop) pressure | Parameter 031 |
| 4) Pump 1 cut-in (start) pressure | Parameter 032 |
| 5) Pump 2 cut-in (start) pressure | Parameter 033 |

Set to boosting mode, parameters 030 to 034 are in bar
These are the control pressures in in the delivery line

Example:

Full measuring range:	25 bar
Over pressure alarm value:	8 bar
Pump 1 cut-in (start) pressure:	4 bar
Pump 2 cut-in (start) pressure:	2.5 bar
Pump cut-out (stop) pressure:	5.5 bar

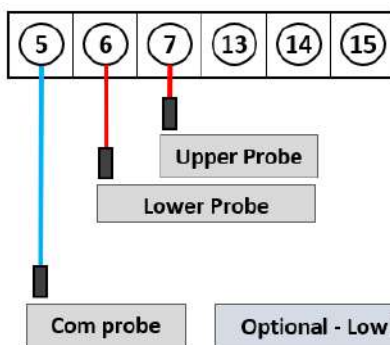

OR

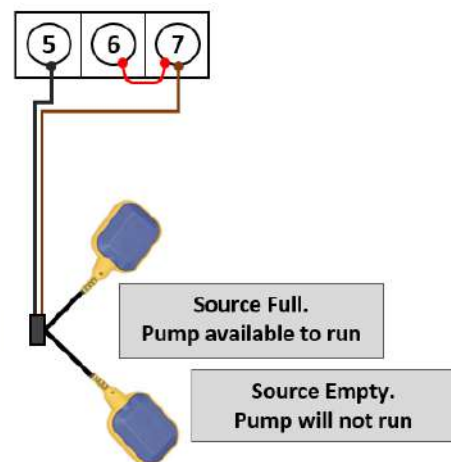

19. Backup power supply

In some regions battery backup for the high-level alarm is mandated.

Connecting a 24v battery pack will maintain the alarm and control circuit in case of a mains power failure.

When mains power falls, the unit will display in input voltage (24V) and the Under-Voltage warning message will display on the screen. The pump will not attempt to run, the backup power supply is only to ensure the Hi-Level alarm is able to function for as long as the backup battery maintains its output

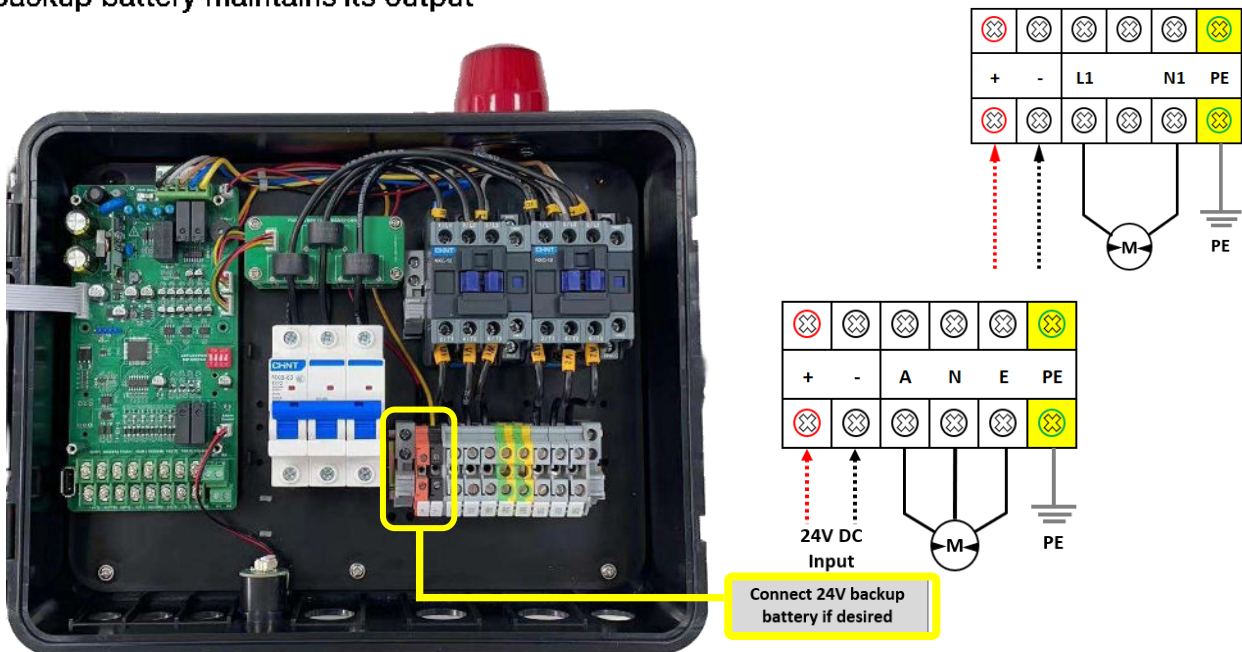

External Alarm

The PLC has an inbuilt audible alarm.

The External Audible / Visual alarm light supplied with the nXt DPC Pro panel receives pulses of 24V DC power from the PLC (JB2, JB3).

An additional 24V DC external, remote alarm can be fitted and wired in parallel. PN 811785

Alarm test:

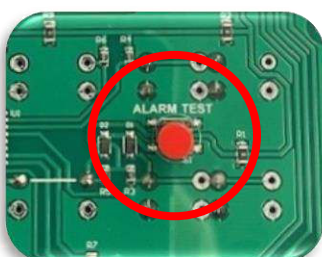







Located on the rear of the display PCB is an alarm test button.



20. Fault Messages

Fault Message	Possible Cause	Potential Solutions
UNDER V	The actual running voltage is lower than the calibrated voltage parameter 024 . The pump is in an under-voltage protection state	The controller will attempt to restart the pump every 5 minutes until line voltage is restored to normal If this fault occurs repeatedly, report low line voltage to the power supply company
OVER V	The actual running voltage is higher than the calibrated voltage parameter 025 . The pump is in over-voltage protection state	The controller will attempt to restart the pump every 5 minutes until line voltage is restored to normal If this fault occurs repeatedly, report high line voltage to the power supply company
PUMP STALLED	The pump motor running amperage has exceeded the normal (calibrated) running amperage by more than parameter 022 (default value 175%) This could be due to physical jamming or a mechanical issue. If the pump stalled error occurs repeatedly at commissioning check the controller rating is matched to the pump	Pump Stalled is a 'critical error' and will not automatically reset. Isolate the power supply and inspect the pump for anything which has caused the sudden increase in load
OVER LOAD	Pump motor running amperage exceeds the normal (calibrated) running amperage by more than parameter 021 (default value 135%)	Isolate the power supply and inspect the pump for anything which is causing the pump to draw more amperage than the initial calibration value
UNDER LOAD	Pump motor running amperage is less than the normal (calibrated) running amperage by more than parameter 020 (default value 75%)	Under-load is sometimes referred to as Dry-run protection as a pump motor will draw less current when there is no load.
OPEN PHASE	The power supply has lost a phase.	Check fuses and wiring.
PHASE IMBALANCE	Three phase model only The incoming voltage (ampere) between three phases (R/S/T) differs by more than $\pm 15\%$	The controller will attempt to restart the pump every 4 minutes until the voltage (amperage) between three phases is restored to normal
POWER PHASE REVERSAL	Three phase model only Sequence of the incoming wiring (R/S/T) is incorrect	Change the sequence of the wiring
PUMP NO CALIBRATION	Calibration not complete	Check the calibration Parameters 018 and 019

21. Accessories

Image	Description	Part #
	Capacitance Probe	805321
	4-20mA pressure transducer 1MPA	802680
	4-20mA level transducer 2m	804528
	SK12(5M) H05 10 amp SK12(10M) H05 10 amp SK12(20M) H05 10 amp SK12(30M) H05 10 amp FSK1 (5m) H07 10 amp FSK1 (10m) H07 16 amp FSK1-20 (20m) H07 16 amp	700965 700962 700963 700964 809941 700610 700611
	FSK1.1(10m) H07 10 amp	801125
	Float switch counter-weight	700967
	Pressure switch (NC) 6 bar Pressure switch (NC) 12 bar Reverse acting pressure switch (NO) 5.5 bar Reverse acting pressure switch (NO) 10 bar	701440 701380 809863 809864

22. Warranties – Terms and Conditions

This warranty is given in addition to the consumer guarantees found within the Australian Competition and Consumer Act 2010 (Cth) for goods purchased in Australia and the Consumer Guarantees Act 1993 NZ for goods purchased in New Zealand:



1) White International Pty Ltd / White International NZ Ltd (White International) warrant that all products distributed are free from defects in workmanship and materials, for their provided warranty period as indicated on the top or opposite side of this document. Subject to the conditions of the warranty, White International will repair any defective products free of charge at the premises of our authorised service agents throughout Australia and New Zealand if a defect in the product appears during the warranty period. If you believe that you have purchased a defective product and wish to make a claim under this warranty, contact us on our Sales Hotline on 1300 783 601, or send your claim to our postal address or fax line below and we will advise you as to how next to proceed. You will be required to supply a copy of your proof of purchase to make a claim under this warranty.

2) This warranty excludes transportation costs to and from White International or its appointed service agents and excludes defects due to non-compliance with installation instructions, neglect or misuse, inadequate protection against the elements, low voltage or use or operation for purposes other than those for which they were designed. For further information regarding the suitability of your intended application contact us on our Sales Hotline on 1300 783 601. If you make an invalid claim under this warranty, the original product will be sent back to you unrepai red.

3) This warranty refers only to products sold after the 1st January 2012, and is not transferable to another product type and only applies to the original owner, purchaser or end user, and is in addition to the consumer guarantees found within the Competition and Consumer Act 2010 (Cth) for goods purchased in Australia and the Consumer Guarantees Act 1993 (NZ) for goods purchased in New Zealand.

4) Our goods come with guarantees that cannot be excluded under the Australian Consumer Law. You are entitled to a replacement or refund for a major failure and for compensation for any other reasonably foreseeable loss or damage. You are also entitled to have the goods repaired or replaced if the goods fail to be of acceptable quality and the failure does not amount to a major failure. 2 YEAR WARRANTY

5) To the fullest extent permitted by law, White International excludes its liability for all other conditions or warranties which would or might otherwise be implied at law. To the fullest extent permitted by law, White International's liability under this warranty and any other conditions, guarantees or warranties at law that cannot be excluded, including those in the Competition and Consumer Act 2010 (Cth), is expressly limited to: (a) in the case of products, the replacement of the product or the supply of equivalent product, the payment of the cost of replacing the product or of acquiring an equivalent product or the repair of the product or payment of the cost of having the product repaired, is at the discretion of White International or a 3rd party tribunal elected under the Competition and Consumer Act 2010 (Cth) for goods purchased in Australia and the Consumer Guarantees Act 1993 (NZ) for goods purchased in New Zealand; and

6) To the fullest extent permitted by law, this warranty supersedes all other warranties attached to the product or its packaging.

7) In the case of services, supplying the services again or the payment of the cost of having the services supplied again, is at the discretion of White International or a 3rd party tribunal elected under the Competition and Consumer Act 2010 (Cth) for goods purchased in Australia and the Consumer Guarantees Act 1993 (NZ) for goods purchased in New Zealand. 8) Our warranty commences from the date of purchase of the above-mentioned pumps. Proof of purchase is required before consideration under warranty is given.

Record your date of purchase in the space below and retain this copy for your records.

Date of Purchase**Model Purchased**



www.whiteint.com.au

1300 783 601

www.whiteint.co.nz

0800 509 506

Please always refer to our website for further technical information & new product innovations

Disclaimer: Every effort has been made to publish the correct information in this manual. No responsibility will be taken for errors, omissions or changes in product specifications.

© 2024 Copyright White International Pty Ltd

TM ® - WARNING: Please be aware that various brands & products depicted within this document are subject to trademark, patent or design registrations. Infringement of any intellectual property contained within this document without express written authority by the appropriate intellectual property holder may result in further legal action to be taken. For any queries regarding use of the contained information please feel free to contact White International Pty Ltd.