

PRODUCT DATA SHEET

BIA B45VAS2 • 802768



BRAND

BIANCO
PUMPZ

PRODUCT DETAILS

The BIA B45VAS2 is a rugged vortex type drainage pump fitted with a cast iron semi vortex impeller. With a free passage of 25mm this pump is suitable for general drainage applications with clean or slightly dirty water and can tolerate some stringy material or non abrasive particles in suspension.

Ideal for greywater pump out and flooded irrigation, sump emptying, septic transfer and pumping of light slurries.

BENEFITS

- Bianco Pumpz represents 'best in class', dependable pumping solutions
- Easy to install and use

FEATURES

- Automatic Operation
- Quality pump materials and construction to ensure reliable operation
- Carry handle
- Industrial grade coating
- 10m H07RN-F Neoprene power lead and float lead

TECHNICAL DATA

RATED POWER (W)	450W
MAX. FLOW [LPM]	200 lpm
MAX. HEAD [M]	8.5m
WORKING TEMPERATURE	< 35°C
LIQUID TEMPERATURE	2°C - 35°C
MAX. IMMERSION DEPTH	5m
MAX. DIA. OF PARTICLE	< 25mm
MOTOR DUTY	S1 Continuous
MOTOR PROTECTION LEVEL	Class B
MOTOR PROTECTION	In-built auto re-setting thermal overload
CAPACITOR	18 uF +/-5% 450V

RATED VOLTAGE	220V-240V 50 Hz
RATED CURRENT	3.7A @ 230V
POWER CABLE TYPE	10m H07RN-F
PROTECTION CLASS	IP68
IMPELLERS	Single Cast Iron Impeller
HYDRAULIC BODY	Cast Iron
OUTLET	2" DN with universal hose tail
SEALS	Dual Mechanical Seal and lip seal
AUTOMATION FUNCTION	Flexible Float Switch
NET WEIGHT (KG)	Pump only 19.3 kg
PACKAGE DIMENSION	195L x 265W x 540H (mm)

HYDRAULIC PERFORMANCE

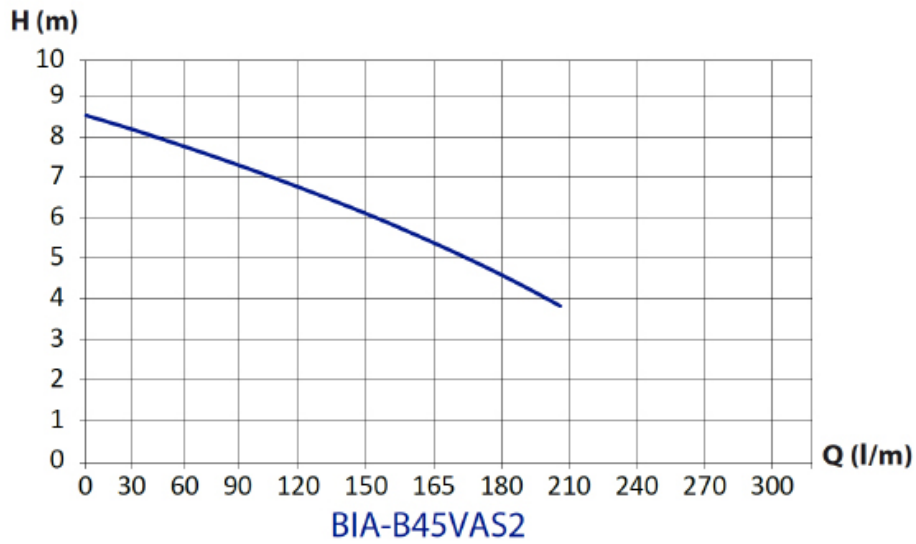

DIMENSIONS

HEIGHT

450 mm high

PUMP DIAMETER

160 mm

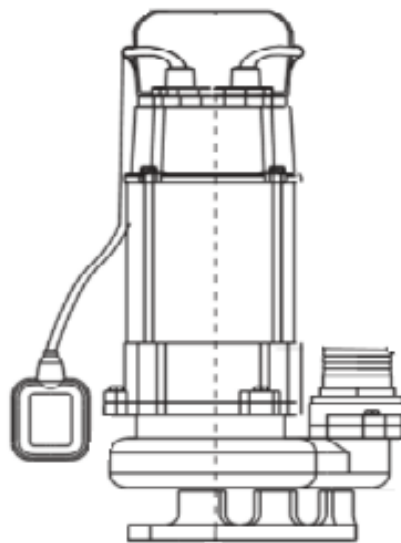

OUTLET

2" DN Universal Hose Tail

WIDTH

243mm total

WARRANTY / CERTIFICATIONS

