

GENERAL INFO

WHOLE HOUSE SINGLE WATER FILTER SYSTEM

Affordable whole house system that turns your rainwater into great tasting water at every tap.

A whole house filter system designed for the budget-conscious householder. Suited to small to medium households, these systems are designed for both mains and rainwater supply. These systems reduces chlorine, taste, odour, chemicals and sediment from your water.

FEATURES & BENEFITS

- Designed for alternative water supplies.
- No power required, no moving parts, easy to maintain.
- Dual purpose carbon cartridge that removes both sediment and bad taste & odour.
- Can be used for both mains and rainwater supply.



EM1-60

Single Stage Filtration, 60 Lpm, 1" connection



EM1-110

Single Stage Filtration, 110 Lpm, 1½" connection

Ordering Code	EM1-60	EM1-110
Replacement Cartridge:	DP10MP1	DP10MP2
Flow Rate:	60 Lpm	110 Lpm
Min/max Temperature:	0 - 52°C	0 - 52°C
Min/max Pressure:	100 - 875 kPa	100 - 875 kPa
Connection:	1" BSP [25mm]	1½" BSP [40mm]
Warranty:	10 years [^]	10 years [^]

Important Note: Use only genuine Puretec replacement cartridge.

DIAGRAM & FILTRATION TECHNOLOGY

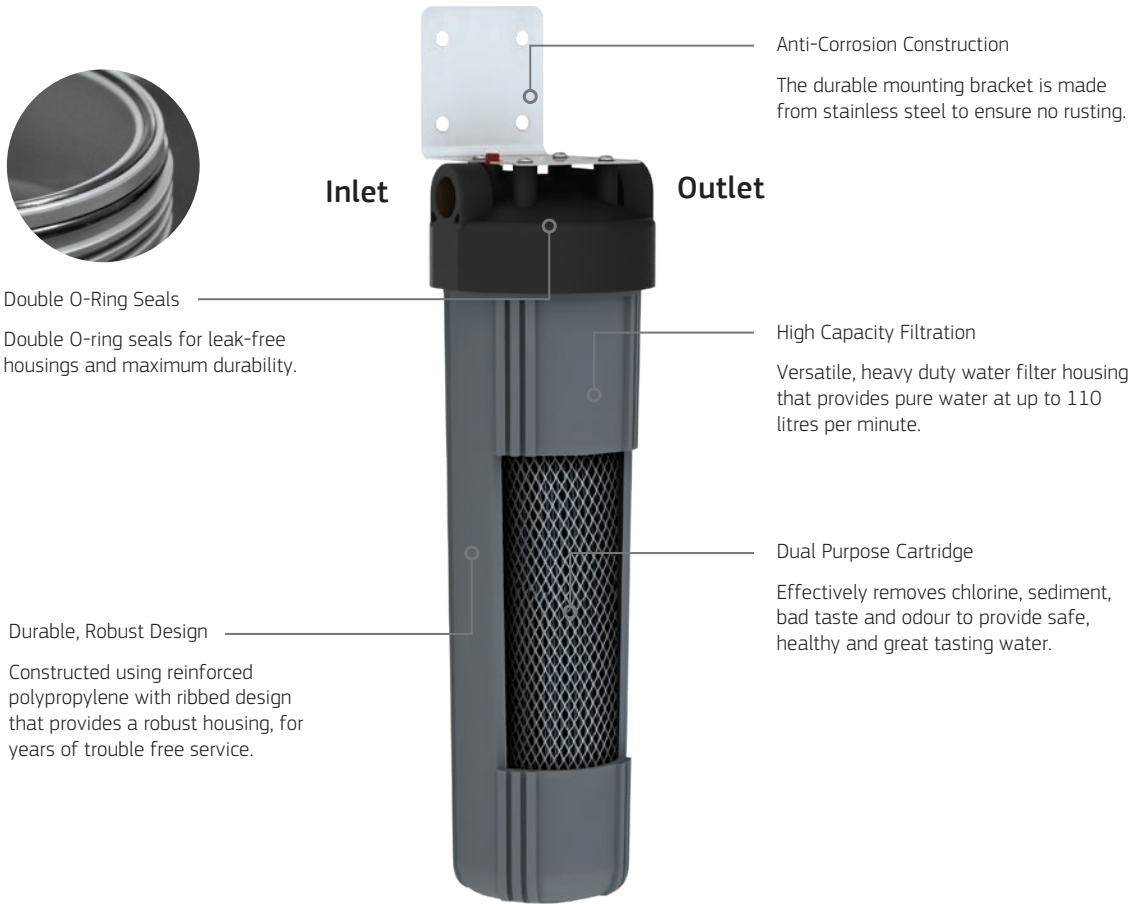

A whole house system that filters your rainwater throughout the house. These systems are designed for the budget-conscious householder, giving good general purpose filtration.

It reduces taste, odour, chemicals and sediment in your water. These systems also protect and prolong the life of appliances throughout your home.



Highly effective and efficient at removing dirt, rust, sediment, bad taste and odour in your water, providing good general purpose filtration.

PRODUCT DIMENSIONS Measurements in Millimeters (mm)

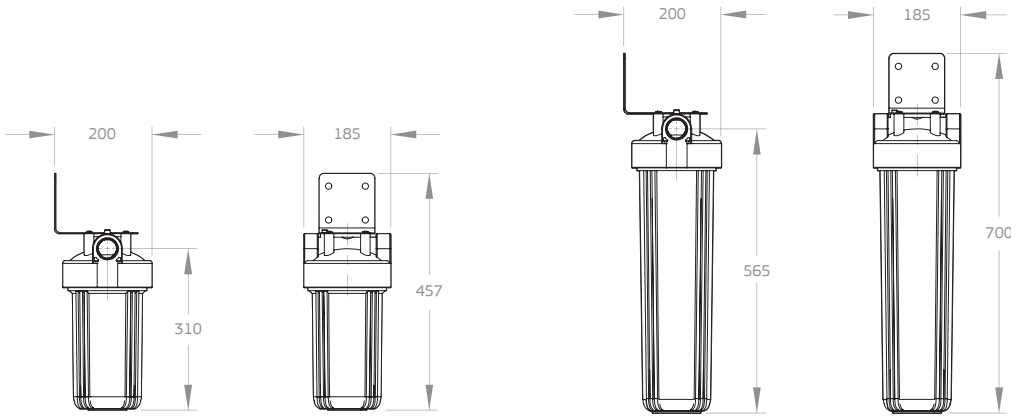

EM1-60

EM1-110



WaterMark

AS/NZS 3497
Licence No. WM 74617
Australian Certification Services
*Filter Housings

- Note:**
1. No claims can be made based on the specifications and images in this document. The design, technology, colours, features and prices are subject to change.
 2. This document and all its contents are copyright protected. All rights are reserved, particularly alteration, translation and reproduction using electronic systems.
 3. ^Warranties in this document cover parts for the period stated and include cover for parts and labour for the first year where applicable, subject to approval. Plus 9 years parts only. Our Water Filtration Specialists can provide you with advice to suit your needs.