

The pump is a self-priming surface mounted pressure system pump supplied with plug and play leads (IEC type). The self-priming ability provides excellent suction capacity of up to 9m. Used especially for supplying water to domestic applications

Model Number: ASC J40/60
Item Number: 809465

Pump Data

Pressure Rating: 4.0 bar | 400kPa
Min. fluid temp: 2° C
Max. fluid temp: 40° C
Max. operating temperature: 40° C

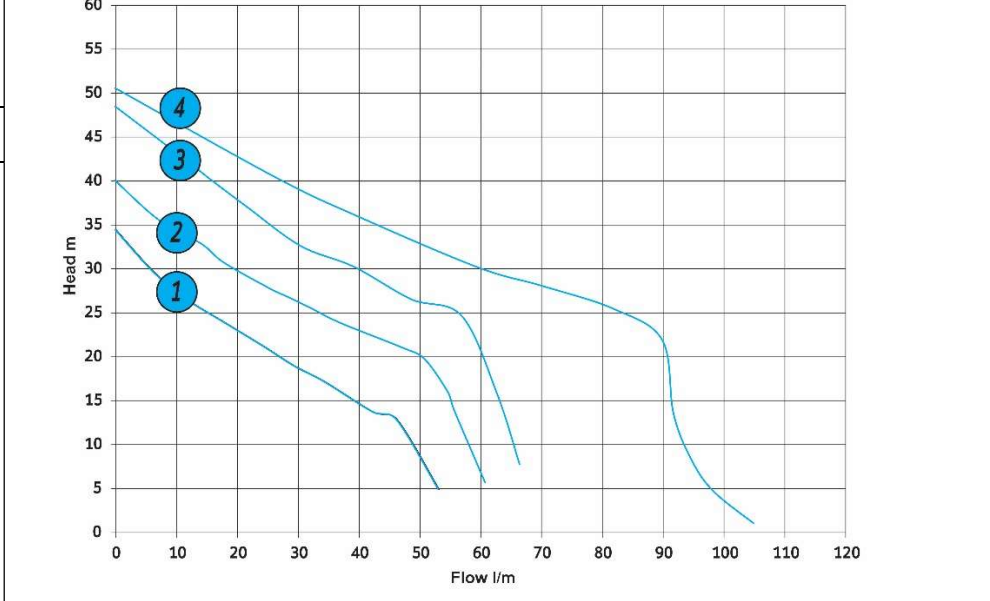

1 ASC-J35/50 2 ASC-J40/60 3 ASC-J48/65 4 ASC-J50/100

Max Flow Rate: 61LT/min
Max Head: 40m
Fluid: Water, pure
Density: 998.3 kg/m³

Materials

Pump Body: 304 Stainless
Support: Cast Aluminium
Motor Body: Cast Aluminium
Mechanical Seal: Carbon / Ceramic
Jet / Venturi: Polypropylene
Impeller: Polypropylene
O Ring: Nitrile
Power Cable: 1.2m H05

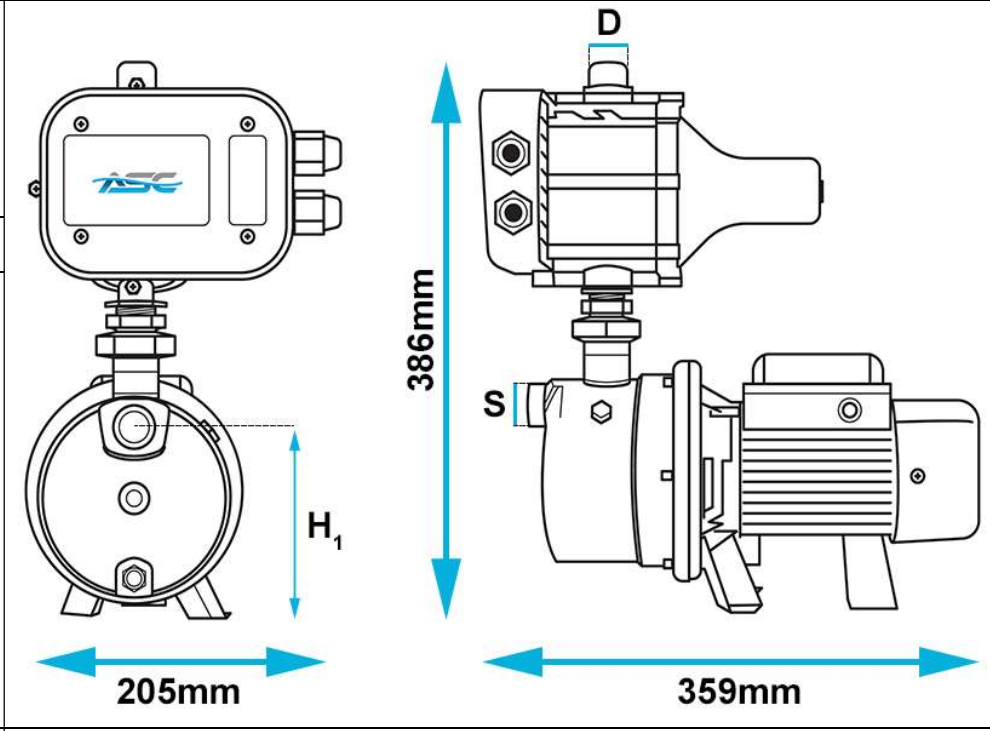

Electrical Data

Phase: Single Phase 1ø
Rated Voltage: 220-230V ~

Dimensions (mm)

A (length)	359mm	S	25mm
B (width)	205mm	D	25mm
H (height)	386mm		
H ₁ (centre)	145mm		

Mains Frequency:	50Hz	Boxed Weight: Pump Weight:	10.30kg
P2 (kW):	550W		12.16kg
HP:	0.75hp		
Current:	2.39A		
Capacitor:	15μF		
VL:	450V		
Motor Duty:	Continuous		
Motor Type:	Asynchronous		
Ingress Protection:	TEFC		
Insulation Class:	IP X4		
Motor Protection:	B In-built thermal overload		

ASC Water Tanks reserves the right to make modifications without notice.