



**Company name:** ASC Water Tanks  
**Created by:** Anant Yuvarajah  
**Phone:** 03 8795 7715  
**Email:** anant@asctanks.com.au  
**Date:** 9/10/2023

**Qty. Description**

1 UNILIFT AP12.50.11.A1



**Note! Product picture may differ from actual product**

Product No.: [96023931](#)

Submersible drainage pump type

Vertical single-stage stainless steel submersible pump with vertical discharge port and integrated submersible 1-phase totally enclosed motor in insulation class F with thermal overload protection.

The pump is fitted with suction strainer and level switch for automatic start and stop.

The impeller is a SEMI OPEN impeller for groundwater, surface water, rain water and similar.

The pump has a double shaft seal and an intermediate oil chamber pre-filled with non-toxic special oil.

The pump has a riser pipe, a cooling jacket for continuous cooling of the motor by the pumped liquid and long-life deep-groove greased-for-life ball bearings.

The pump is ready for use as it is fitted with carrying handle and is supplied with a 10 m mains cable. The mains cable is of the plug type with glass sealing compound in the socket to prevent penetration of humidity into the stator windings.

**Liquid:**

Liquid temperature range: 0 .. 55 °C

Density: 998.2 kg/m<sup>3</sup>

**Technical:**

Maximum flow: 500 l/min

Type of impeller: SEMI OPEN

Max. Particle: 12 mm

Approvals: CE,RCM,LGABG,EAC,TUVRHWID

Rated speed: 2760 rpm

**Materials:**

Pump housing: Stainless steel  
EN 1.4301



**Company name:** ASC Water Tanks  
**Created by:** Anant Yuvarajah  
**Phone:** 03 8795 7715  
**Email:** anant@asc tanks.com.au  
**Date:** 9/10/2023

Qty.	Description
1	<p>AISI 304 Stainless steel EN 1.4301</p> <p>AISI 304 Cable union: Brass CW602N C35330</p> <p>Installation: Range of ambient temperature: 0 .. 55 °C Type of connection: Rp Size of connection: 2 inch Maximum installation depth: 7 m Place of installation: Indoor/outdoor</p> <p>Electrical data: Power input P1: 1.7 kW Motor type 1-phase: PSC Rated power - P2: 1.1 kW Mains frequency: 50 Hz Rated voltage: 1 x 220-240 V Rated current: 8.5 A Cos phi - power factor: 0.92 Rated speed: 2760 rpm Capacitor size - run: 20 µF/400 V Enclosure class (IEC 34-5): IP68 Insulation class (IEC 85): F Length of power cable: 10 m Type of cable plug: AU</p> <p>Others: Net weight: 15.3 kg Gross weight: 16.2 kg Country of origin: DK Custom tariff no.: 8413709019182742 Environmental approvals: WEEE</p>



Company name: ASC Water Tanks  
Created by: Anant Yuvarajah  
Phone: 03 8795 7715  
Email: anant@asc tanks.com.au  
Date: 9/10/2023

### 96023931 UNILIFT AP12.50.11.A1 50 Hz

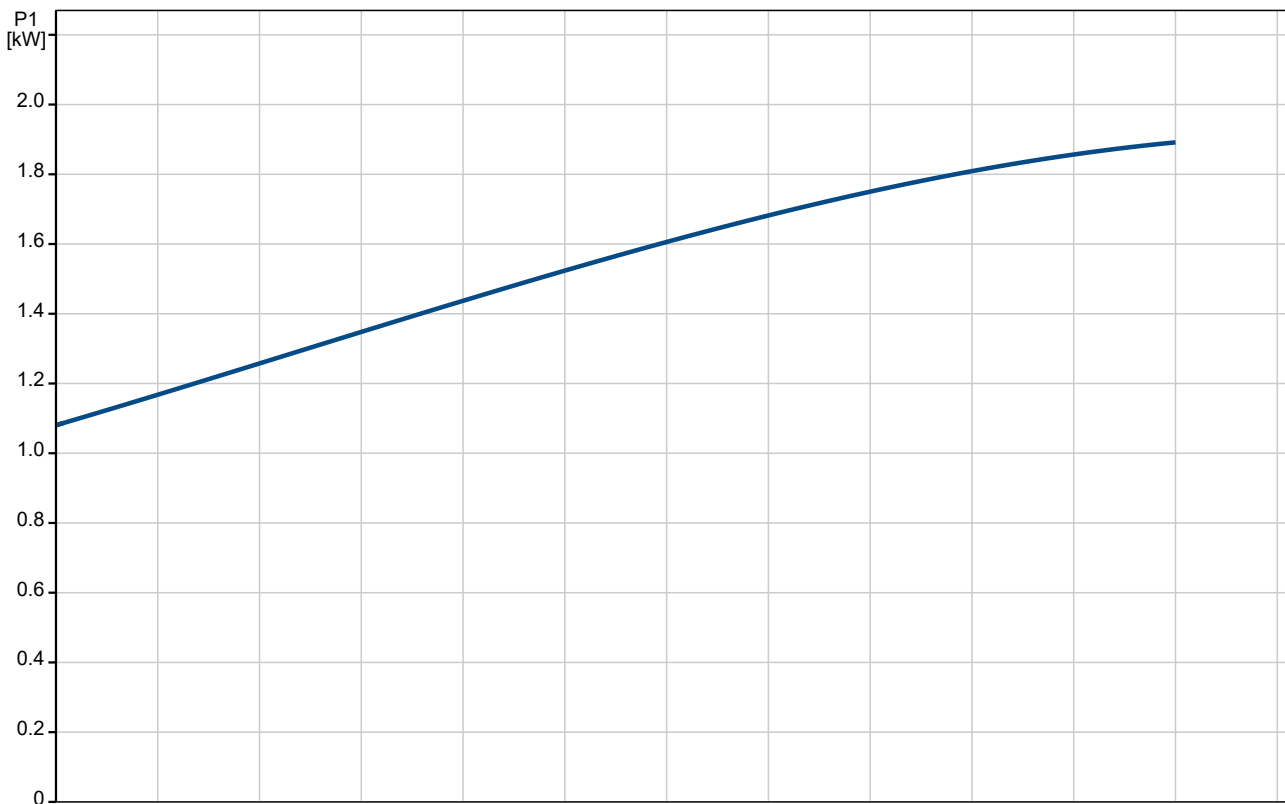
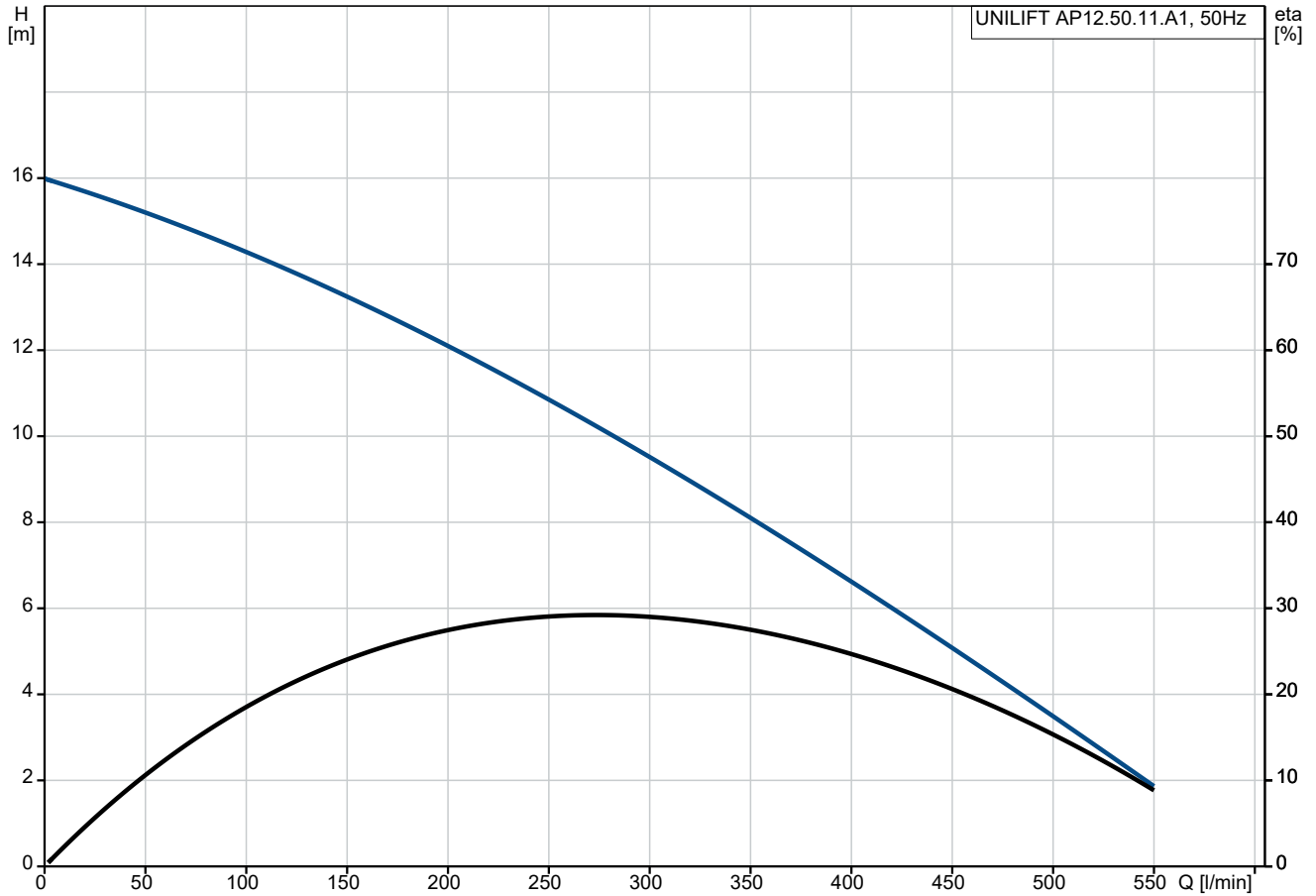



**Company name:** ASC Water Tanks  
**Created by:** Anant Yuvarajah  
**Phone:** 03 8795 7715  
**Email:** anant@asc tanks.com.au  
**Date:** 9/10/2023

Description	Value
<b>General information:</b>	
Product name:	UNILIFT AP12.50.11.A1
Product No:	96023931
EAN number:	5700390549046
Price:	AUD 1698
<b>Technical:</b>	
Maximum flow:	500 l/min
Maximum head:	17 m
Type of impeller:	SEMI OPEN
Max. Particle:	12 mm
Approvals:	CE,RCM,LGABG,EAC,TUVRHWD
Rated speed:	2760 rpm
<b>Materials:</b>	
Pump housing:	Stainless steel
Pump housing:	EN 1.4301
Pump housing:	AISI 304
Impeller:	Stainless steel
Impeller:	EN 1.4301
Impeller:	AISI 304
Cable union:	Brass
Cable union:	CW602N
Cable union:	C35330
<b>Installation:</b>	
Range of ambient temperature:	0 .. 55 °C
Type of connection:	Rp
Size of connection:	2 inch
Maximum installation depth:	7 m
Place of installation:	Indoor/outdoor
<b>Liquid:</b>	
Liquid temperature range:	0 .. 55 °C
Density:	998.2 kg/m <sup>3</sup>
<b>Electrical data:</b>	
Power input P1:	1.7 kW
Motor type 1-phase:	PSC
Rated power - P2:	1.1 kW
Mains frequency:	50 Hz
Rated voltage:	1 x 220-240 V
Rated current:	8.5 A
Cos phi - power factor:	0.92
Rated speed:	2760 rpm
Capacitor size - run:	20 µF/400 V
Enclosure class (IEC 34-5):	IP68
Insulation class (IEC 85):	F
Built-in motor protection:	CONTACT
Thermal protec:	internal
Length of power cable:	10 m
Type of cable plug:	AU
<b>Controls:</b>	
Level switch:	float switch
<b>Others:</b>	
Net weight:	15.3 kg
Gross weight:	16.2 kg
Sales region:	Australia
Country of origin:	DK
Custom tariff no.:	8413709019182742
Environmental approvals:	WEEE

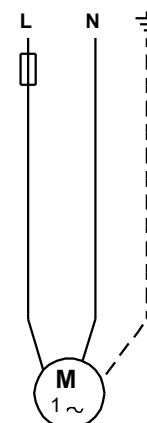
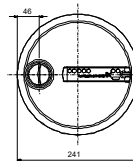
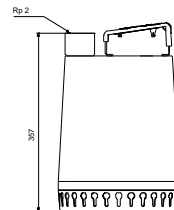
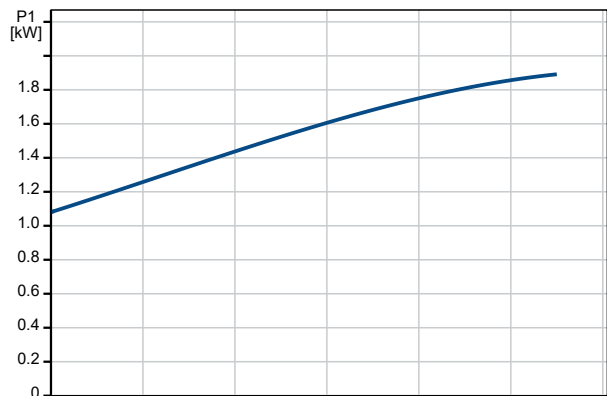
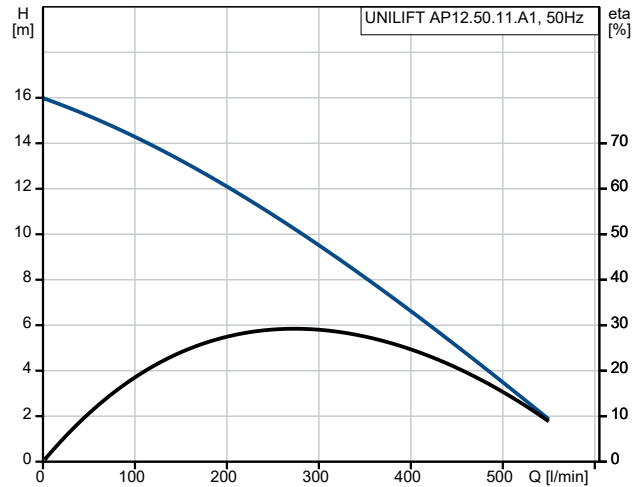



Company name: ASC Water Tanks  
Created by: Anant Yuvarajah  
Phone: 03 8795 7715  
Email: anant@asc tanks.com.au  
Date: 9/10/2023

### 96023931 UNILIFT AP12.50.11.A1 50 Hz

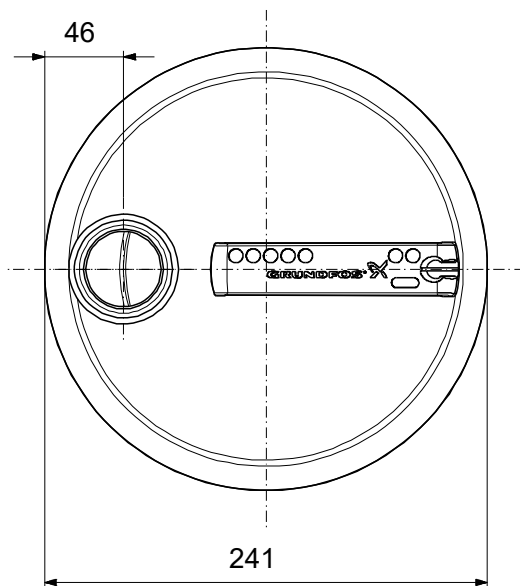
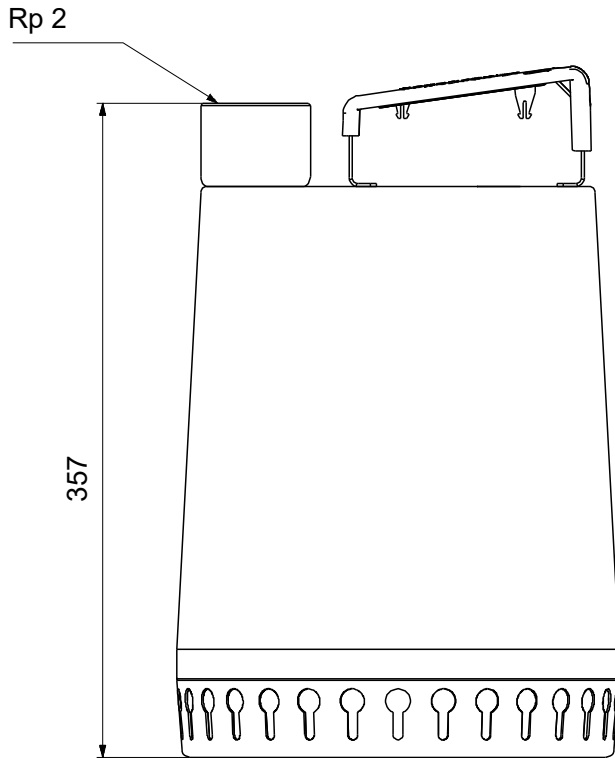

Note! All units are in [mm] unless others are stated.  
Disclaimer: This simplified dimensional drawing does not show all details.