

Qty. Description

1 SOLOLIFT2 CWC-3



Note! Product picture may differ from actual product

Product No.: [97775326](#)

Sololift2 CWC-3 is a small, compact automatic lifting station suitable for pumping of wastewater off places in private dwellings where wastewater cannot be led directly to the sewer by means of a natural downward slope.

Sololift2 CWC-3 is typically used for:

- wall-hung toilets, cabinet showers and washbasins in basements below sewer level, in connection with the renovation or modernisation of existing buildings, where the location may be remote from the main soil pipe so that a natural slope cannot be established.

Extremely low switching levels for lowest construction heights, advantageously in case of connection of a shower receptor.

Sololift2 CWC-3 is suitable for installation in a hollow space behind a wall-hung toilet.

This lifting station is only suitable for pumping wastewater from a cabinet shower and a washbasin as well as sewage water from a toilet containing toilet paper and faeces.

The pumping of liquids containing other material may cause faults and limit the scope of our guarantee.

The compact lifting station is equipped with

- Cable with or without plug (see technical data)
- Horizontal or vertical fastening possibility of discharge hose connector with several adaptors for pipes with Ø22-40mm
- integrated non return valve
- Dry and high performance motor unit incl. thermal protection, pressure switch and controller
- DN100 toilet connection hose
- Flexible connectors for inlet (adjustable in height) of pipes Ø36 or 40
- Slot for an alarm board with buzzer (accessory)
- Manual anti clogging function and separate drain connection for service
- Venting valve with overflow protection
- Uplift fixation clips

Design according to EN12050-3 and production inspection by external institute with unique features focused on quick installation, long lasting operation and easy clean service.

Liquid:

Liquid max temp: 50 °C

Density: 998.2 kg/m³

Technical:

Approvals on nameplate: CE,TR,VDEEMV,VDE,MORO

Curve tolerance: ISO9906:2012 3B

Materials:

Tank: Plastic

Installation:

Pump inlet: 32/36/40, 36/40/50, DN 100

Pump outlet: 22/25/28/32/36/40

Number of leads: 3X0,75MM2

Electrical data:



Company name:

Created by:

Phone:

Date:

19/09/2022

Qty.	Description
------	-------------

1	Power input - P1: 620 W
	Mains frequency: 50 Hz
	Rated voltage: 1 x 220-240 V
	Rated current: 3 A
	Cos phi - power factor: 0.92
	Rated speed: 2800 rpm
	Enclosure class (IEC 34-5): IP44
	Insulation class (IEC 85): F
	Length of cable: 1.2 m
	Cable type: H05VV-F-3G
	Type of cable plug: AUSTRALIEN
	Others:
	Net weight: 7.94 kg
	Gross weight: 9.69 kg

97775326 SOLOLIFT2 CWC-3 50 Hz

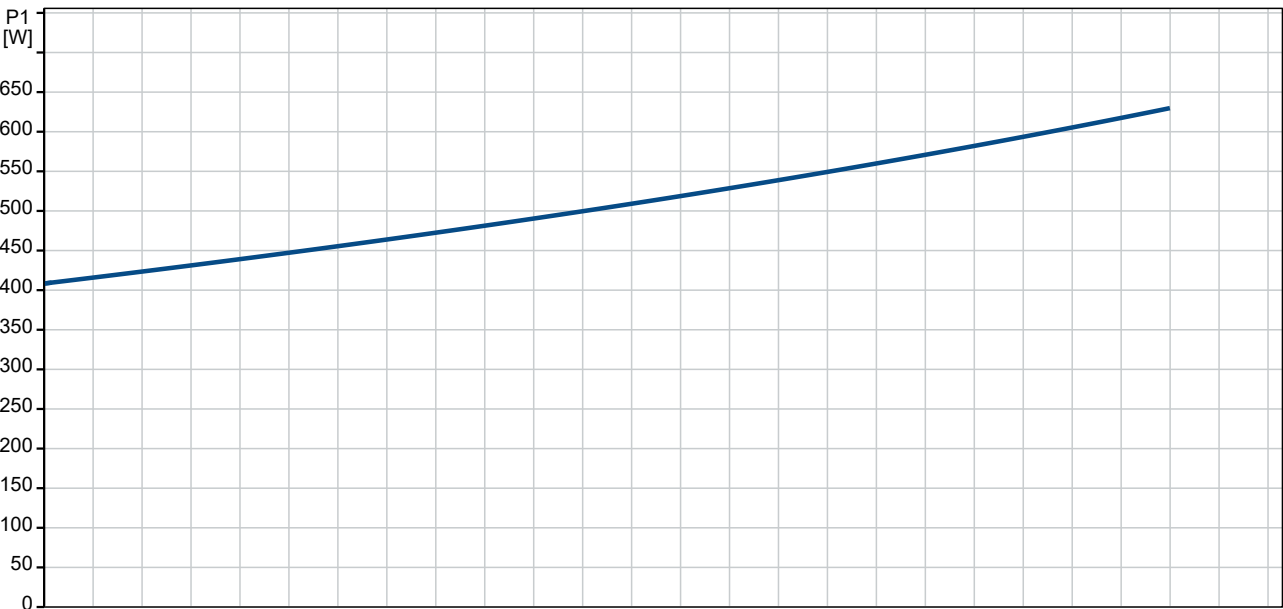
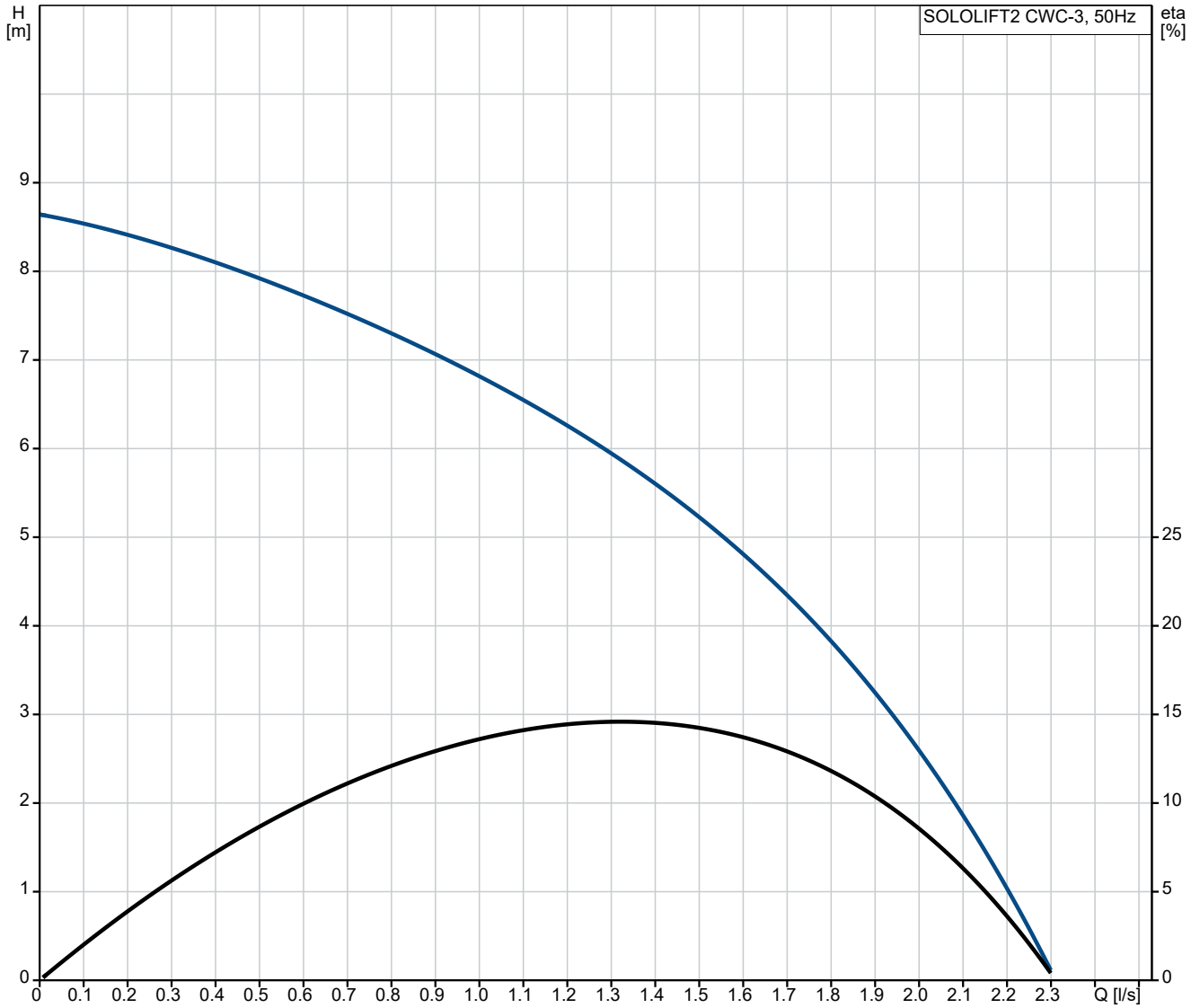

Description	Value
General information:	
Product name:	SOLOLIFT2 CWC-3
Product No:	97775326
EAN number:	5710624187357
Technical:	
Head max:	8.5 m
Approvals on nameplate:	CE,TR,VDEEMV,VDE,MORO
Curve tolerance:	ISO9906:2012 3B
Materials:	
Tank:	Plastic
Installation:	
Pump inlet:	32/36/40, 36/40/50, DN 100
Pump outlet:	22/25/28/32/36/40
Number of leads:	3X0,75MM2
Liquid:	
Liquid max temp:	50 °C
Density:	998.2 kg/m ³
Electrical data:	
Power input - P1:	620 W
Mains frequency:	50 Hz
Rated voltage:	1 x 220-240 V
Rated current:	3 A
Cos phi - power factor:	0.92
Rated speed:	2800 rpm
Enclosure class (IEC 34-5):	IP44
Insulation class (IEC 85):	F
Thermal protec:	THERMIK S06-150-05
Length of cable:	1.2 m
Cable type:	H05VV-F-3G
Type of cable plug:	AUSTRALIEN
Others:	
Net weight:	7.94 kg
Gross weight:	9.69 kg
Product range:	Australia

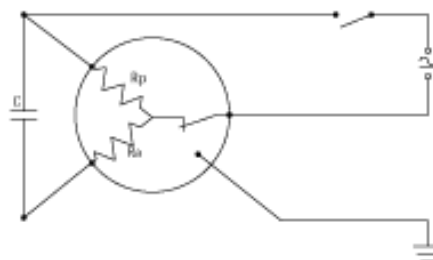
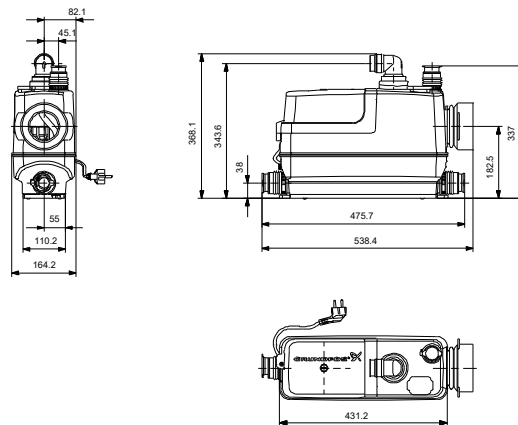
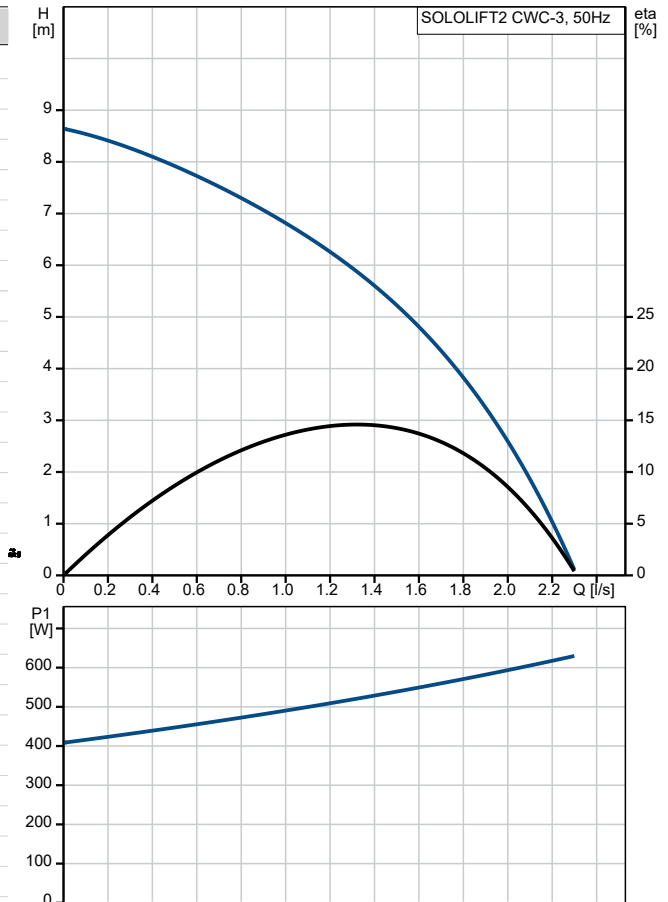

97775326 SOLOLIFT2 CWC-3 50 Hz

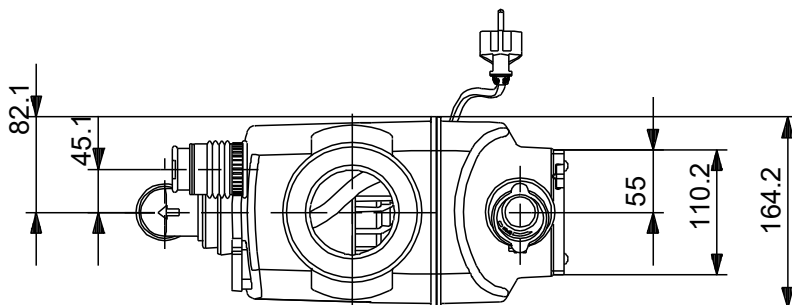
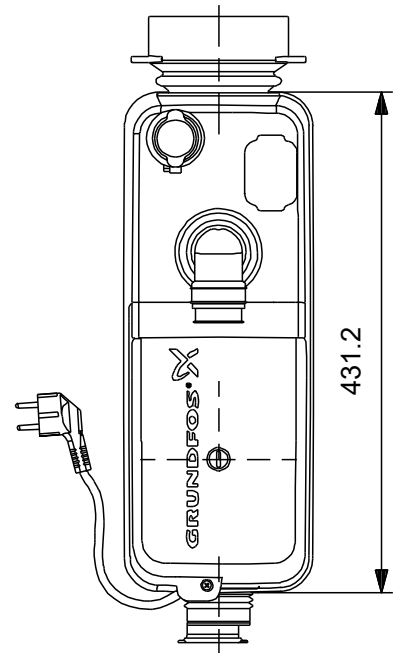
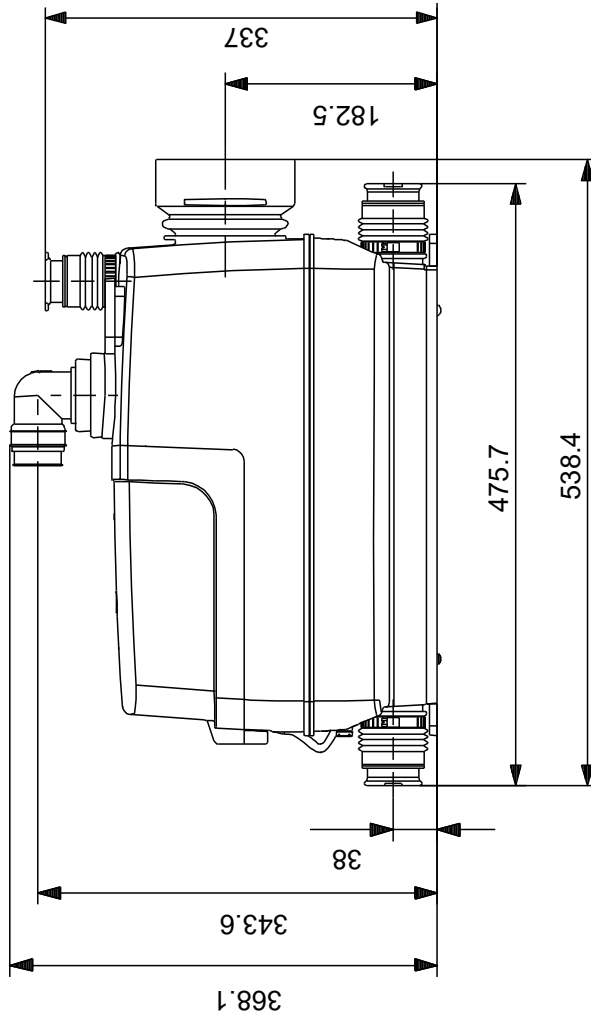

Note! All units are in [mm] unless others are stated.
Disclaimer: This simplified dimensional drawing does not show all details.

97775326 SOLOLIFT2 CWC-3 50 Hz

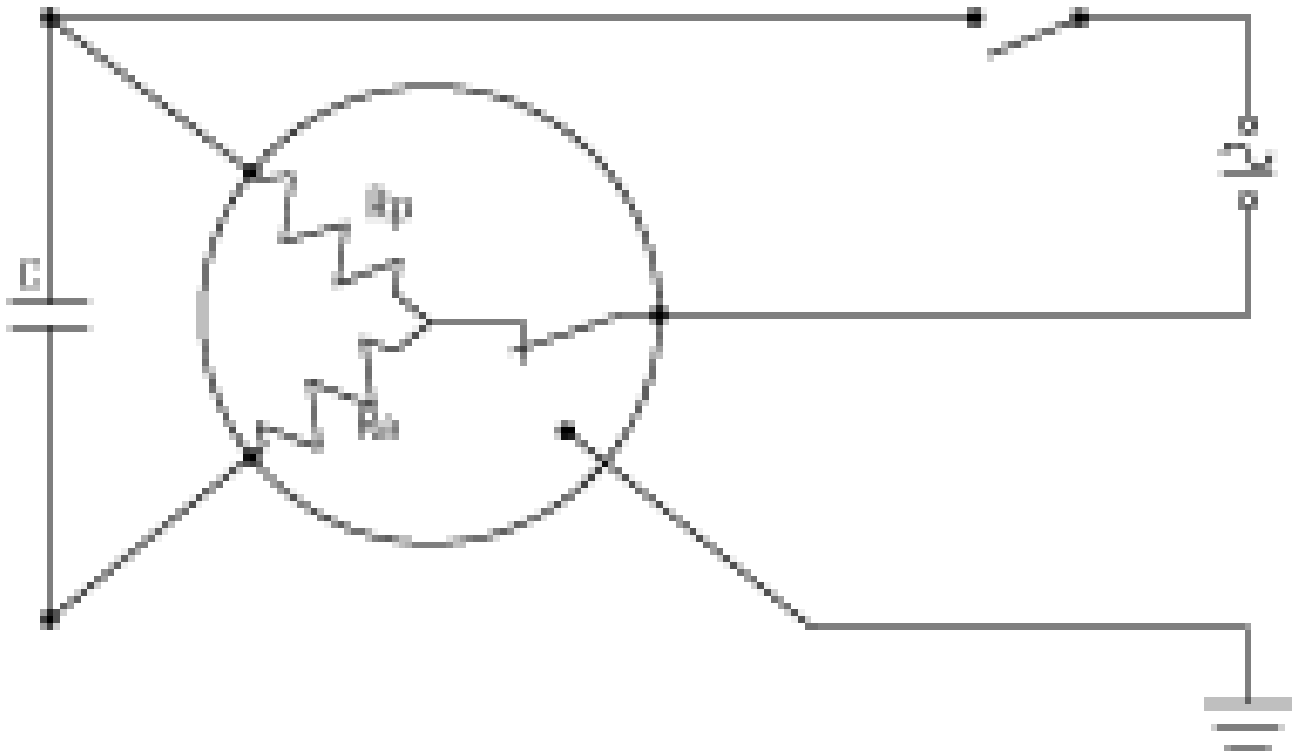

Note! All units are in [mm] unless others are stated.