

ITEM NO.	PRODUCT CODE	DESCRIPTION	QTY.
1	PCST5000	5000L SLIMLINE TANK	1
2	S4	400mm LEAF STRAINER	1
3	OFF9	OVERFLOW PVC FLANGED 90MM	1
4	LH01	25mm [1"] BRASS BSP TANK OUTLET	1

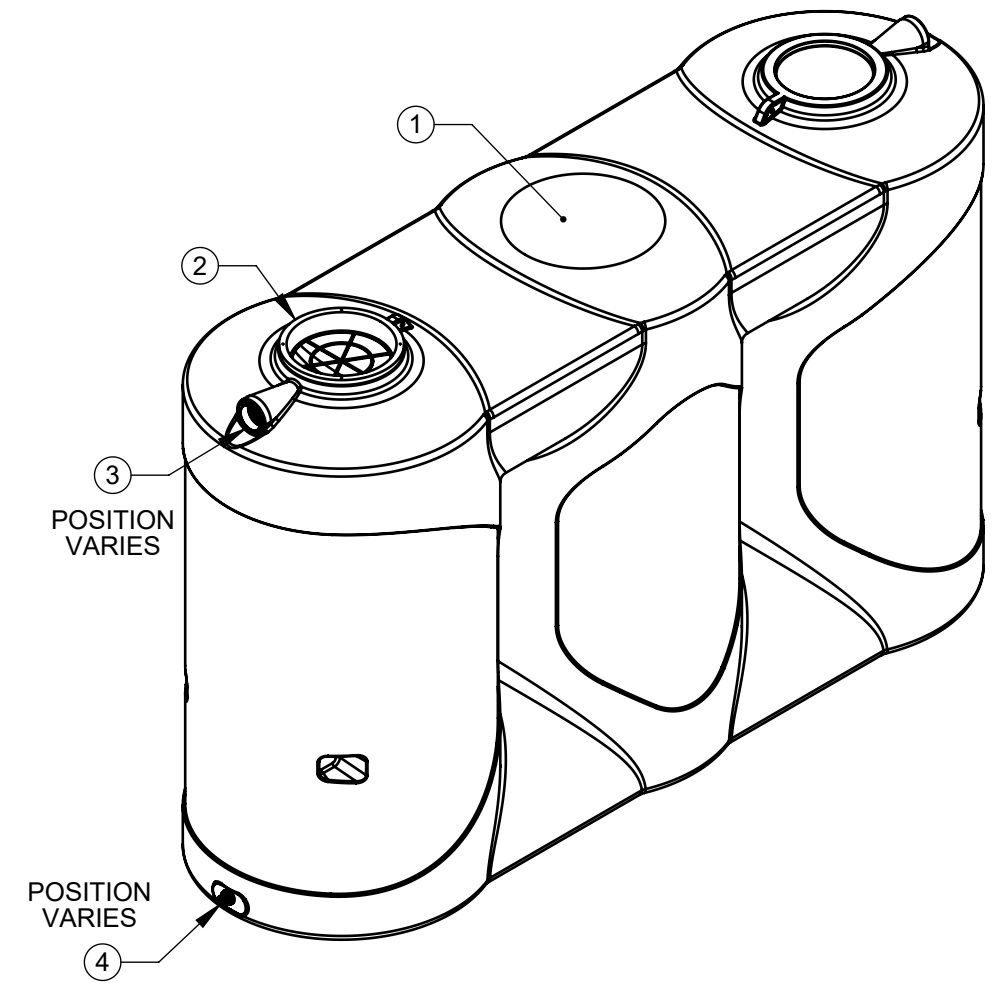
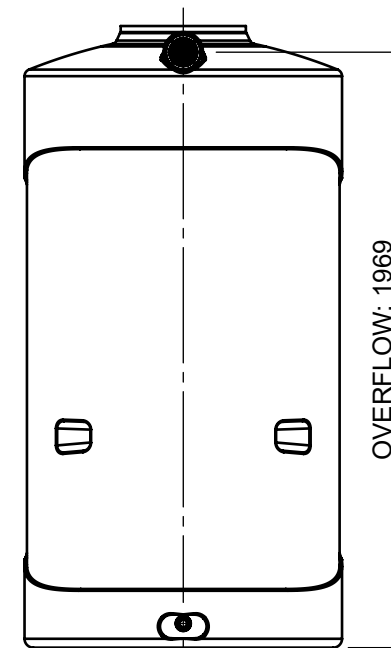
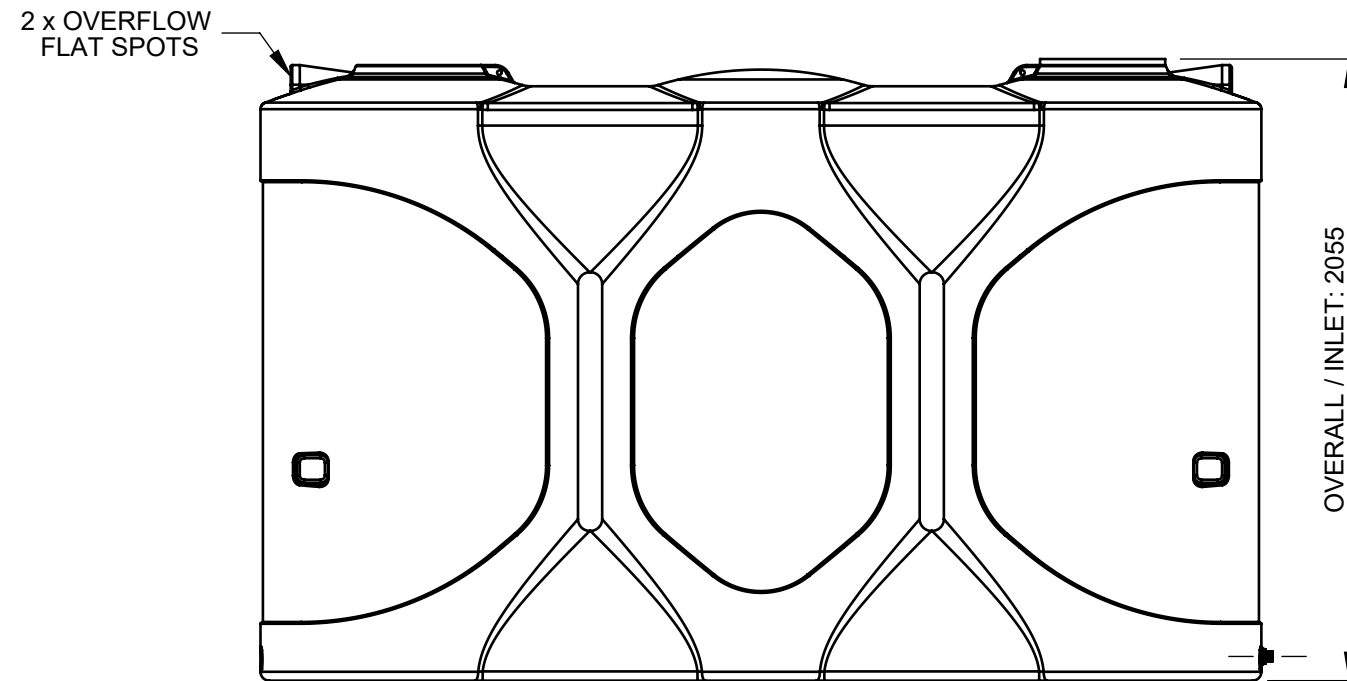
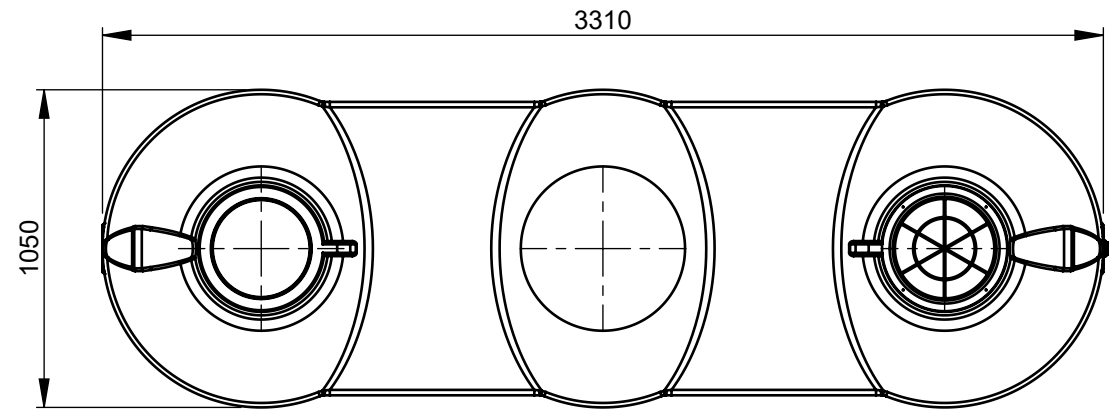

ISOMETRIC VIEW

NOTE:
DUE TO SHRINKAGE VARIATIONS IN MANUFACTURE,
ALL MEASUREMENTS ARE APPROXIMATE ONLY.

NOTE: ALL TOLERANCES UNLESS OTHERWISE STATED $\pm 10\text{mm} / \pm 1^\circ$
DO NOT SCALE, USE DIMENSIONS. ALL DIMENSIONS ARE IN mm

This drawing is the property of Polymaster Group Pty. Ltd. It cannot be copied
in part or in full without the written permission of Polymaster Group Pty. Ltd.

© POLYMASTER GROUP



161 KARINIE STREET
SWAN HILL. VIC.
3585
Ph: (03) 5033 9000
Fx: (03) 5033 0224

DESCRIPTION	5000L RAINWATER SLIMLINE TANK	A3 SHEET SIZE	SCALE: 1:25
PRODUCT CODE	PCST5000		
MATERIAL			
COLOUR			
DRAWING No.	PCST5000 GA		
DRAWN	MV	6/28/2022	1/1 Rev: B