

The pump is a horizontal multistage surface mounted pressure system pump supplied with a 1.2m Australian power plug and a 2.2 bar cut in automatic restart pressure controller. The pump must be used for flooded suction application. Used especially for supplying water to domestic applications.

Model Number: ASC M38/50
Item Number: 810206

Pump Data	
Pressure Rating:	3.5 bar 350kPa
Min. fluid temp:	4° C
Max. fluid temp:	85° C
Max. operating temperature:	40° C

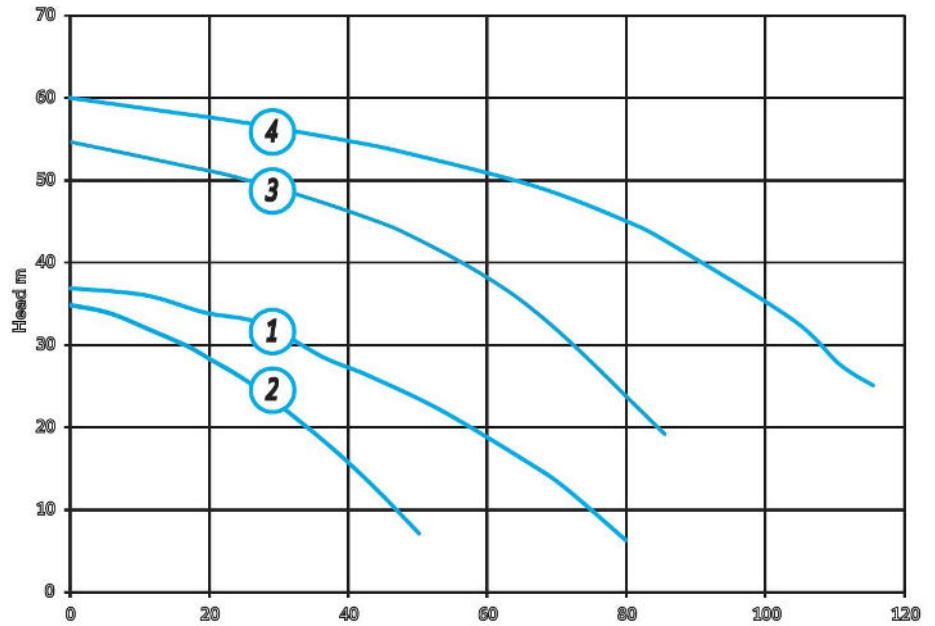

- 1 ASC-M37/80
- 2 ASC-M38/50
- 3 ASC-M55/85
- 4 ASC-M60/120

Max Flow Rate:	50LT/min
Max Head:	35m
Fluid:	Water, pure
Density:	998.3 kg/m ³

Materials	
Pump Body:	Stainless Steel
Support:	Cast Aluminium
Motor Body:	Cast Aluminium
Mechanical Seal:	Graphite / Silicon / Carbide
Impeller:	Stainless Steel
O Ring:	Nitrile
Power Cable:	1.2m H05

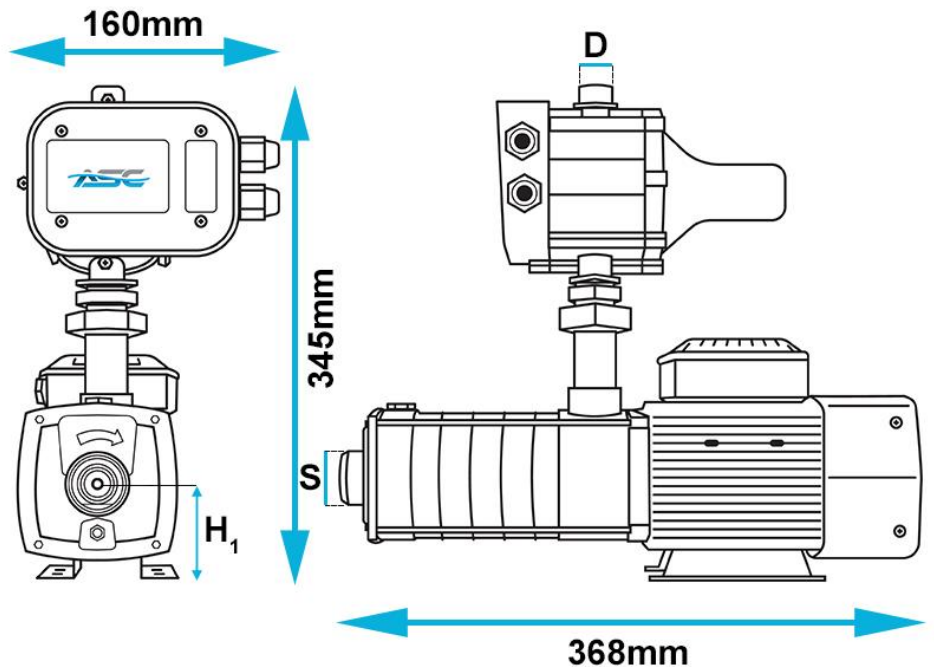

Electrical Data

Dimensions (mm)

Phase:	Single Phase 1 ϕ	A (length)	368mm	S	25mm
Rated Voltage:	220-230V ~	B (width)	160mm	D	25mm
		H (height)	345mm		
		H ₁ (centre)	76mm		

Mains Frequency:	50Hz	Boxed Weight: Pump Weight:	13.78kg 12.28kg
P2 (kW):	370W		
HP:	0.5 hp		
Current:	1.54A		
Capacitor:	12μF		
VL:	450V		
Motor Duty:	Continuous		
Motor Type:	Asynchronous		
Ingress Protection:	TEFC		
Insulation Class:	IP 54 Motor		
Motor Protection:	B In-built thermal overload		

ASC Water Tanks reserves the right to make modifications without notice.