

PRODUCT DIMENSIONS

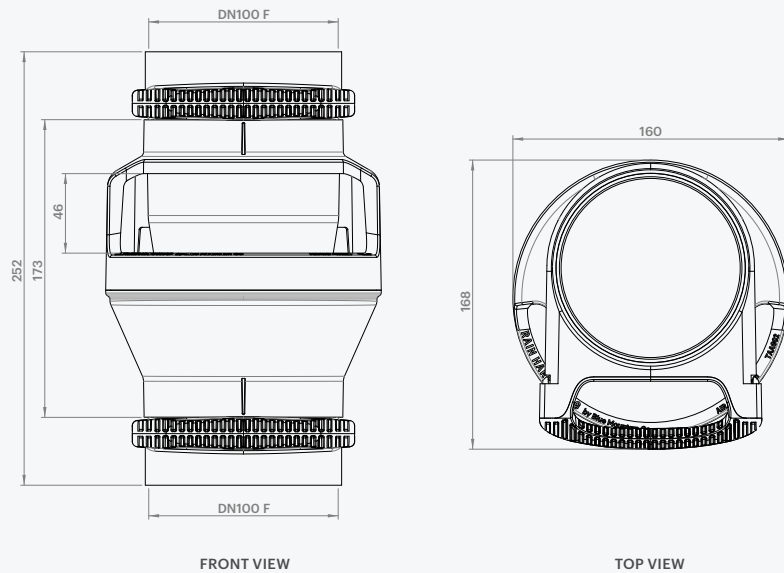

ALL DIMENSIONS IN MM UNLESS OTHERWISE STATED.

Pipe Fitment

TAAG02	DN100 F (socket)	100mm pipe fits inside
--------	------------------	------------------------

DISCLAIMER This product specification is not a complete guide to product usage. Further information is available from Rain Harvesting Pty Ltd and from the Installation and Operating Instructions. This specification sheet must be read in conjunction with the Installation and Operating Instructions and all applicable statutory requirement. Product specifications may change without notice. © Rain Harvesting Pty Ltd.

RAIN HARVESTING

by Blue Mountain Co

+61 (0)7 3248 9600

rainharvesting.com.au

RAIN HARVESTING
by Blue Mountain Co

Air Gap 100mm



Installation and Specification Guide

PRODUCT DETAILS

Protect your rainwater from contamination by preventing stormwater backflow – and mosquitoes – entering your tank through your outlet pipes.

TAAG02 100mm

FEATURES AND BENEFITS

- Prevent stormwater backflow from entering your tank and contaminating your rainwater
- Prevent mosquitoes, frogs, rats and pests from entering your tank through your overflow
- Easy maintenance with removable upper and lower mosquito proof screens
- Raised lower lip on the air gap opening to minimise splashing

Installation

WHAT'S IN THE BOX?

- Air Gap

TOOLS/MATERIALS YOU MAY REQUIRE

- Marker pen
- Tape measure
- Saw
- Solvent weld glue

AIR GAP

1. Select an installation point for your Air Gap. This must be a vertical section of pipe after your tank overflow.
2. There is 3 parts to your Air Gap (2 x insect proof screens and 1 x main body). Please remove the insect proof screens, then use solvent weld glue to glue the bodies into either end of the main body of the Air Gap.
3. Remove a 220mm section of pipe at your desired installation point. The Air Gap assembly incorporates two 100mm female sockets that glue directly to 100mm pipe. Ensure all cut edges are clean and smooth.
4. Orient your Air Gap so it is the right way up as shown in the diagram on the right. The mouth of the Air Gap catches the water flowing from the tank.
5. Apply solvent weld glue to inside the sockets of the Air Gap and also outside of each pipe.
6. Fit the Air Gap into position and insert both pipes into the sockets and hold until glue sets.

MAINTENANCE

Remove the insect proof screens by pulling the handle and clean off any build up of debris.

REFERENCE CHART

1. Removable insect proof screen for easy cleaning
2. Main body

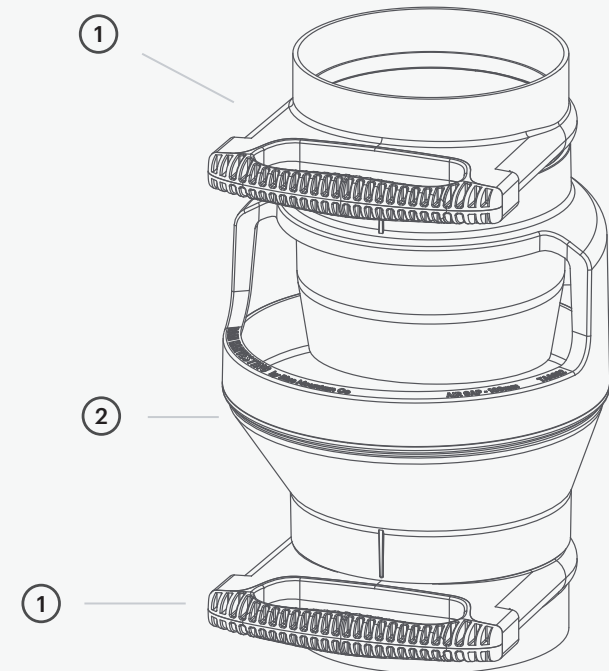

COMPLIANCE

- AS/NZS 4020:2005 – Testing of products for use in contact with drinking water