



Auto Restart Pump Controller
iCON NXT User Manual
808034 / BIA-NXT



1. Introduction

Thank you for choosing the **iCON NXT** Intelligent Pump Controller.

The **iCON NXT** Controller is a digital pump pressure controller suitable for controlling single phase pumps up to a maximum of 10 amps (approx. 1.5kW).

The **iCON NXT** Controller starts the pump by registering water pressure drop and stops the pump when flow through the controller falls sufficiently.

Pressure controllers are an alternative to the conventional pressure tank, pressure switch control method.

The chief benefit of a pressure controller over a pressure switch is the in-built dry-run protection and reduced pressure fluctuation due to pump cycling i.e. the pressure remains constant for a given flow.

2. Key Features

- Electrical components are completely isolated from the water flow.
- The Digital display provides real time information of the pressure OR can provide a visual indication of whether there is flow or not.
- Built in pump protection:
 - Prevents the pump from starting and stopping too often.
 - Anti-seize function if pump has not operated for some time.
 - Dry run sensing and auto restart function when water supply is available.





3. Contents

1. Introduction	2
2. Key Features	2
3. Contents	3
4. Technical Specifications	4
5. ISO 7010 Symbols used in this manual	4
6. Warnings	5
6.1 Cautions	6
7. Electrical Connections	7
8. Display	8
9. Operation	9
10. Installation	10
11. Priming the system	11
12. Standards and Approvals	11
13. Benefits of fitting a pressure tank	12
14. Controller Dimensions	13
15. Warranties – Terms and Conditions	14
16. Trouble Shooting Guide	15







4. Technical Specifications

	BIA-NXT
Function	On/Off Control
Modes	Single mode non-programmable
Pump Size	Up to 1.5kW 240V Single Phase
Input Power	220 - 240V +/- 6% 1ph 50Hz
Max Amperage	8 amp
Connection Size	1" BSP Male – Swivel union
Pressure Tank	In built accumulation only <i>External tank recommended</i>
Pump Start pressure	Non-adjustable. Pre-set 2.2 bar
Pump stop	Flow less than 0.9 lpm
Maximum pressure	10 bar
Max working temp	50°C
Maximum flow	Tested to 150 lpm
Cable to Pump	Plug and Play <i>Fly lead supplied when purchased as Control Only</i>
Power Cable rating	10 amp
IP Rating	IP65

5. ISO 7010 Symbols used in this manual

	Warning - Electrical safety
	Warning – Potential consequences of use outside of intended application(s). Includes environmental condition warnings.
	Mandatory warning
	Warning to disconnect power
	Read carefully

6. Warnings

	Read the manual carefully before starting and retain for future reference.
	Prior to starting installation or maintenance, the controller must be disconnected from the power supply and pressure relieved from the system including controller, pump and associated pipework.
	Any changes or modification to the wiring must be carried out by suitably qualified personnel.
	A qualified electrician should correctly size and install circuit breakers to protect the power supply. The fitment of additional surge protection is recommended.
	Never open the cover while the controller is connected to electrical supply.
	This appliance is not intended for use by persons (including children) with reduced physical, sensory or mental capabilities, or lack of experience and knowledge, unless they have been given supervision or instruction concerning use of the appliance by a person responsible for their safety. Children should be supervised to ensure that they do not play with the appliance.
	Never connect AC power to the output terminals. This will cause damage to the controller and will not be covered under warranty.

6.1 Cautions

- 6.1.1 Ensure the controller is suitable for the pump (see Section 4. Technical Data).
- 6.1.2 The controller is designed for use with clean water. Contamination including sand or mineral deposits may affect the operation of the controller.
- 6.1.3 Remove any shipping plugs from the suction and discharge ports before use.
- 6.1.4 There are no serviceable parts in the NXT controller and it should not be dismantled.
- 6.1.5 No regular maintenance of the NXT controller is required.
- 6.1.6 Fitment and replacement must be carried out by competent, skilled, qualified personnel.
- 6.1.7 Avoid installing the NXT controller where it could experience the following conditions:
 - i. Where there is significant vibration and/or mechanical shock.
 - ii. Where it could be exposed to corrosive liquids or gasses, or to flammable materials, solvents etc.
 - iii. Extreme heat and cold. Operating range 3°C - 50°C.
 - iv. Protect the controller from rain and moisture.

7. Electrical Connections

Always use an electrical outlet that is protected by Residual Current Device (RCD) Safety Switch with a trip current of 30mA or less. A Safety switch is required by Australian/New Zealand Standard AU/NZS 60335.1-2011. If the supply cord is damaged, it must be replaced by a special cord or assembly available from White International Pty Ltd or its service agent.



The **iCON NXT** is supplied with a 10 amp rated lead and AS/NZ 3112 (Type 1) 3 pin male power plug for connecting to mains power.

The 'Plug and Play' version of the **iCON NXT** is fitted with a 10 amp rated IEC C13 appliance connector.

When the **iCON NXT** is purchased as **CONTROLLER ONLY** it is supplied with a 2 core and earth power cable for connection to the pump's electric motor. This must be connected by a suitably qualified technician.

There is an additional earth wire inside the controller to provide protection in the event of flooding.

Additional Earth Connection



iCON NXT internal wiring connections.



8. Display

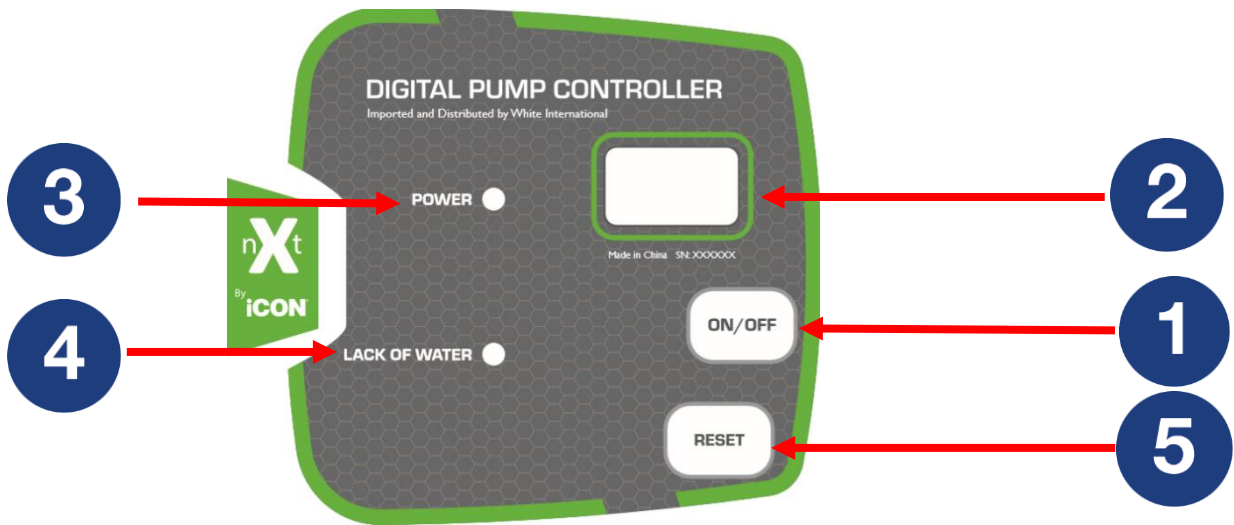

No.	Name	Function
1	ON/OFF	Press button to turn pump controller on Press and HOLD button for 3 seconds to turn the pump controller off
2	DIGITAL DISPLAY	PX.X : Real time pressure in Bar Symbol moving clockwise = Flow (quick press of button 5 to change modes) - - - Symbol stationary = No Flow -P- displayed: Over pressure protection activated -A- displayed: Frequent start protection activated
3	POWER	GREEN LED constant – Power connected
4	LACK OF WATER	RED LED flashing - pump short of water RED LED constant – pump awaiting 24 hour restart
5	RESET	Press and HOLD for 3 seconds to reset software Quick press to change between operation status and pressure reading

9. Operation

When the unit is connected to a power supply the **GREEN** LED “Power On” lights up.

Press the **ON/OFF** button to switch between on and off.

- Press **ON/OFF** button and the pump will attempt to run.
- Press and Hold the **ON/OFF** button for 3 seconds to switch the controller off

*On initial priming the controller may time out on 'dry run' and the **RED "LACK OF WATER"** LED will illuminate. In this event Press and Hold the **RESET** button for 3 sec.*

The **iCON NXT** controller will start the pump automatically when the pressure falls below 2.2 BAR.

The **iCON NXT** controller will stop the pump for 3 reasons:

- Once flow has stopped due to a tap being closed
- In the event that the pump has run out of water
- If the control is subject to over pressure or frequent starts

DRY RUN

If there is no water in tank or a closed supply/suction pipe issue, the **iCON NTX** controller will allow the pump to run for 20 seconds with no flow detected before shutting down.

The **RED LACK OF WATER LED** will **FLASH** and the following sequence will run:

- Stop for 10 seconds
- Run for 40 seconds, Stop for 10 seconds
- Run for 40 seconds, Stop for 10 seconds



After this sequence, the controller will go into auto restart mode and the **RED LED, LACK OF WATER** will stay **ON AND STEADY**



The system will repeat this sequence every 24 hours until flow is detected.

Press and hold the reset button for 3 sec to manually restart the pump.

The **RESET** button allows for the device to be reset without re powering. When the button is pressed for 3 seconds the device will reset any current faults active in the system.

A quick push of the **RESET** button rotates the display indication from the current system pressure to operational status.



10. Installation



Review **SECTION 6 and 6.1 (Warnings and Cautions)** prior to installing

- 10.1 Direction of flow is indicated by an arrow on the inlet and outlet.
- 10.2 The controller has been designed to work with clean water.
- 10.3 Avoid any debris in the pipeline and controller to prevent failure.
- 10.4 The controller can be installed in any orientation so long as the direction of flow is respected.
- 10.5 Ensure the maximum static head (pressure) of water above the controller is less than the starting (cut in) pressure, otherwise the pump will not start.



The controller must be installed on the discharge side of the pump before any outlets/taps.

Installation of the controller must be performed by a suitably qualified technician.

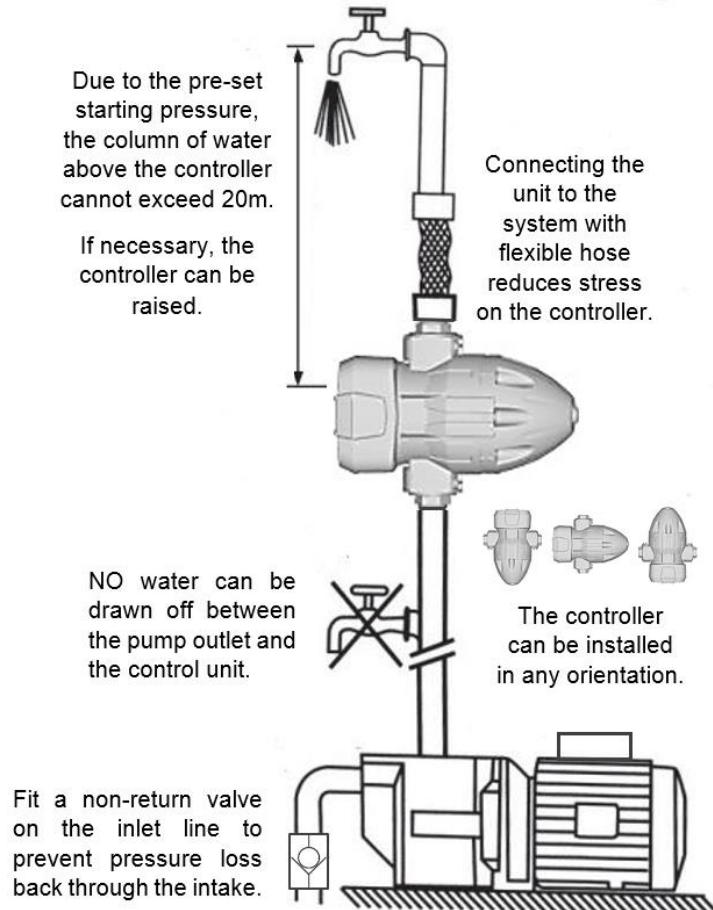

11. Priming the system



The **iCON NXT** is supplied with two 1" BSPT male swivel unions.

The controller can be removed from the pump by removing the stainless steel retaining clip. Once the clip is removed the connection fitting will slide from the controller body.



Due to the non-return mechanism inside the controller, the pump should be primed before fitting the controller OR filled through the pump priming port.

12. Standards and Approvals

	<p>SAA Approvals is accredited by the Joint Accreditation Service of Australia and New Zealand (JAS-ANZ) as a third party certification body to issue of Certificates of Approval for declared and non-declared electrical equipment that has proven to comply with the safety requirements of the applicable Australian Standard.</p>
	<p>Pumps that carry the AS/NZ4020 Drinking Water Approval demonstrate compliance with requirements of Australia & New Zealand Standards of products that come into contact with water intended for human consumption. This approval also ensures that the water coming from the pump will not be contaminated by toxic materials or metals. It also means the water will not support the growth of micro-organisms and will not cause a change in taste or appearance.</p>
	<p>CE marking is a certification mark that indicates conformity with health, safety and environment. The CE marketing represents a manufacturer's declaration that products comply with the EU's New Approach Directives. These directives not only apply to products within the EU but also for products that are manufactured in or designed to be sold in the EEA.</p>

13. Benefits of fitting a pressure tank

The majority of domestic systems have small water losses from dripping tanks, leaking cisterns or feeding low demand items such as ice makers or Reverse Osmosis filtration units.

Simply filling the kettle or pouring a glass of water can cause your pump to start up.

Fitting a small pressure tank to store some pressurised water will reduce the amount of times the pump will need to start.

This has a number of benefits:

- Power saving (reduced power bill!)
- Longer pump life
- Reduced noise
- Protect Piper work from water hammer and thermal expansion

With a pressure control such as the iCON NXT, a 2, 8 or 18 litre tank is recommended.

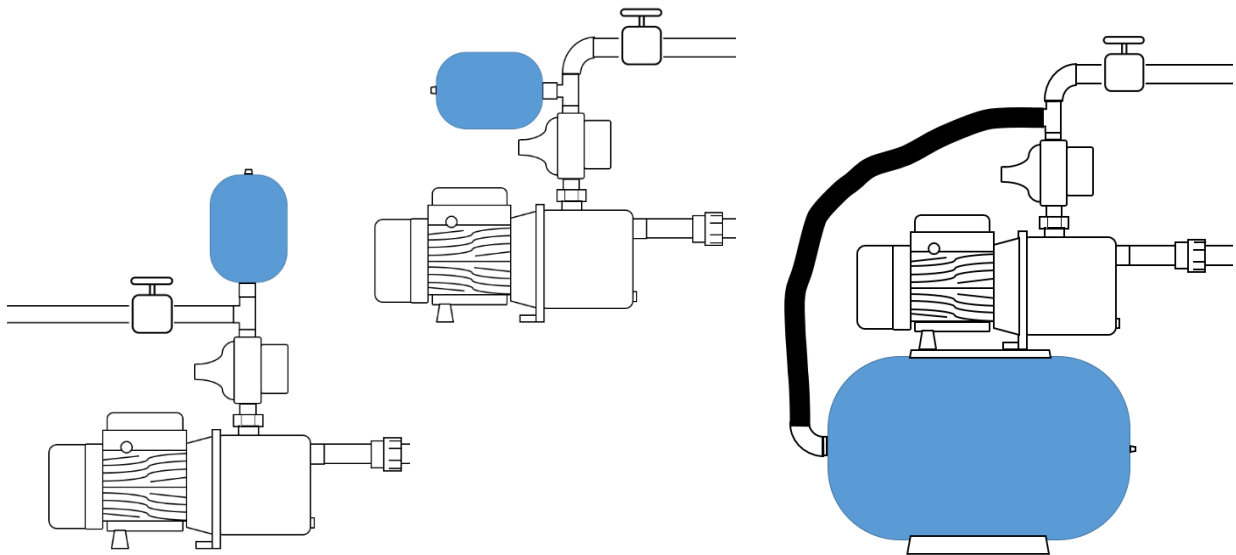

Pressure tanks should never hold more than 1/3 of its total volume as water.

Manufacturers recommend the gas pressure in the tank to be 66% of the maximum system pressure.

Pressure controllers switch off at minimum flow / maximum pump pressure

Pressure tank pre-charge should be set to 66% of full pump pressure.

		CUT IN PRESSURE							
		1.5	2.0	2.5	3.0	3.5	4.0	4.5	5.0
CUT OUT PRESSURE	2.5	1.30	1.80	Green cells - precharge is 20kpa below cut in pressure					
	3.0	1.66	1.80	2.30	Blue cells - precharge is 66.6% of cut out pressure				
	3.5	2	1.80	2.30	2.80				
	4.0	2.33	2.33	2.33	2.80	3.30			
	4.5	2.66	2.66	2.66	2.80	3.30	3.80		
	5.0	3	3	3	2.80	3.30	3.80	4.30	
	5.5	3.33	3.33	3.33	3.33	3.30	3.80	4.30	4.80
	6.0			3.66	3.66	3.66	3.80	4.30	4.80
	6.5			4	4	4	4	4.30	4.80
	7.0			4.33	4.33	4.33	4.33	4.33	4.80
8.0			4.99	4.99	4.99	4.99	4.99	4.99	
9.0			5.66	5.66	5.66	5.66	5.66	5.66	

14. Controller Dimensions

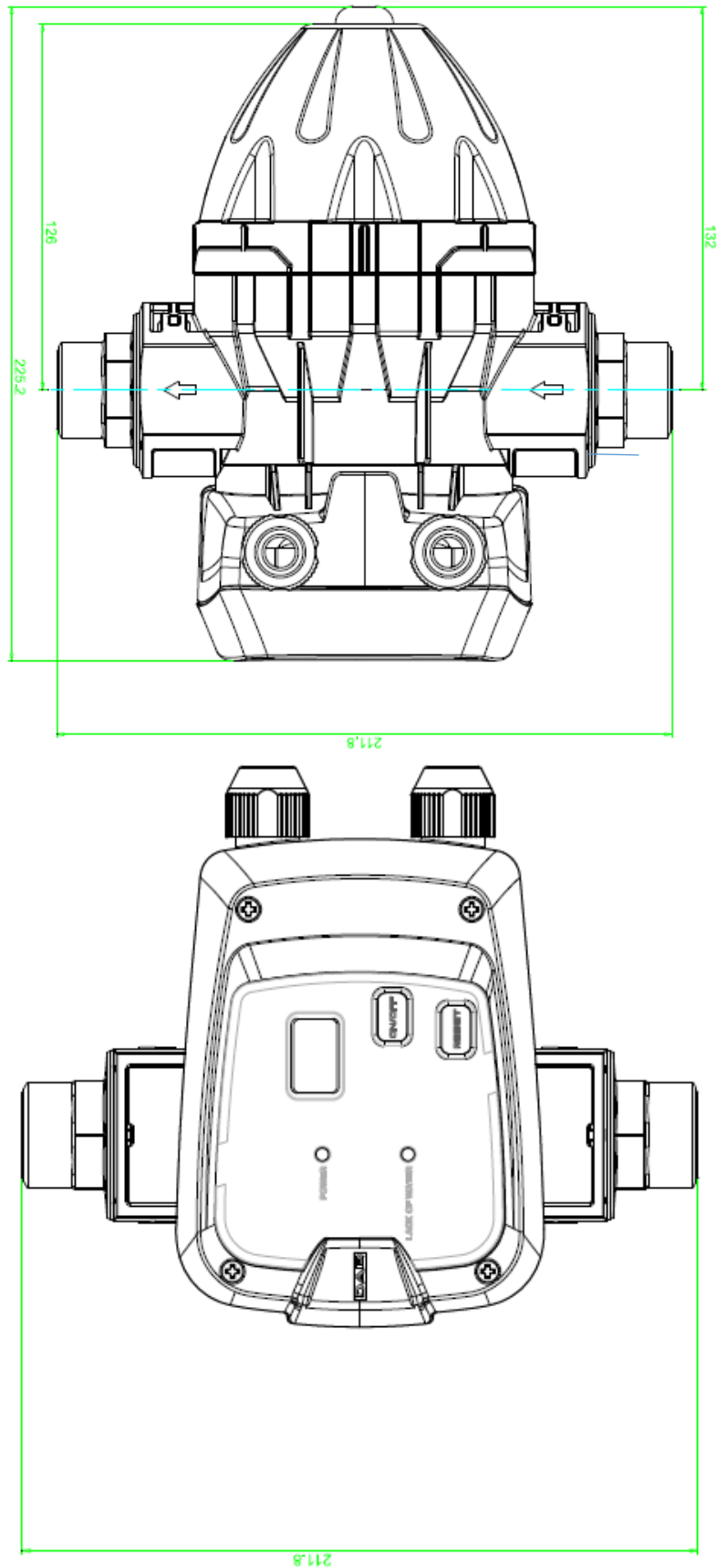

15. Warranties – Terms and Conditions

This warranty is given in addition to the consumer guarantees found within the Australian Competition and Consumer Act 2010 (Cth) for goods purchased in Australia and the Consumer Guarantees Act 1993 NZ for goods purchased in New Zealand:



1) White International Pty Ltd / White International NZ Ltd (White International) warrant that all products distributed are free from defects in workmanship and materials, for their provided warranty period as indicated on the top or opposite side of this document. Subject to the conditions of the warranty, White International will repair any defective products free of charge at the premises of our authorised service agents throughout Australia and New Zealand if a defect in the product appears during the warranty period. If you believe that you have purchased a defective product and wish to make a claim under this warranty, contact us on our Sales Hotline on 1300 783 601, or send your claim to our postal address or fax line below and we will advise you as to how next to proceed. You will be required to supply a copy of your proof of purchase to make a claim under this warranty.

2) This warranty excludes transportation costs to and from White International or its appointed service agents and excludes defects due to non-compliance with installation instructions, neglect or misuse, inadequate protection against the elements, low voltage or use or operation for purposes other than those for which they were designed. For further information regarding the suitability of your intended application contact us on our Sales Hotline on 1300 783 601. If you make an invalid claim under this warranty, the original product will be sent back to you unrepai red.

3) This warranty refers only to products sold after the 1st January 2012, and is not transferable to another product type and only applies to the original owner, purchaser or end user, and is in addition to the consumer guarantees found within the Competition and Consumer Act 2010 (Cth) for goods purchased in Australia and the Consumer Guarantees Act 1993 (NZ) for goods purchased in New Zealand.

4) Our goods come with guarantees that cannot be excluded under the Australian Consumer Law. You are entitled to a replacement or refund for a major failure and for compensation for any other reasonably foreseeable loss or damage. You are also entitled to have the goods repaired or replaced if the goods fail to be of acceptable quality and the failure does not amount to a major failure. 2 YEAR WARRANTY

5) To the fullest extent permitted by law, White International excludes its liability for all other conditions or warranties which would or might otherwise be implied at law. To the fullest extent permitted by law, White International's liability under this warranty and any other conditions, guarantees or warranties at law that cannot be excluded, including those in the Competition and Consumer Act 2010 (Cth), is expressly limited to: (a) in the case of products, the replacement of the product or the supply of equivalent product, the payment of the cost of replacing the product or of acquiring an equivalent product or the repair of the product or payment of the cost of having the product repaired, is at the discretion of White International or a 3rd party tribunal elected under the Competition and Consumer Act 2010 (Cth) for goods purchased in Australia and the Consumer Guarantees Act 1993 (NZ) for goods purchased in New Zealand; and

6) To the fullest extent permitted by law, this warranty supersedes all other warranties attached to the product or its packaging.

7) In the case of services, supplying the services again or the payment of the cost of having the services supplied again, is at the discretion of White International or a 3rd party tribunal elected under the Competition and Consumer Act 2010 (Cth) for goods purchased in Australia and the Consumer Guarantees Act 1993 (NZ) for goods purchased in New Zealand. 8) Our warranty commences from the date of purchase of the above mentioned pumps. Proof of purchase is required before consideration under warranty is given.

Record your date of purchase in the space below and retain this copy for your records.

Date of Purchase**Model Purchased**

16. Trouble Shooting Guide

	Causes unrelated to the controller	Unit related causes
The pump does not start	<p>Voltage Failure (less than 220V)</p> <p>Is the GREEN LED POWER illuminated?</p> <p>Pump no longer operational.</p> <p>Wiring inverted (line/motor)</p>	<p>Ensure the controller ON/OFF button is ON</p> <p>Check the controller isn't in error mode displaying the RED LED LACK OF WATER or showing error message -P- or -A-</p> <p>Ensure the water column above the controller isn't greater than 20m</p> <p>Controller Only option: Check the controller to pump wiring</p> <p>Internal electronics may have failed due to a lightning strike or power surge</p>
The pump doesn't stop	<p>There may be leaks greater than the minimum flow requirement (nominal 0.9 l/min)</p> <p>Note: Check discharge and intake for losses</p>	<p>Inspect the internal check valve</p> <p>Excessive iron oxide disrupting operation</p> <p>Internal electronics may be damaged</p>
Pump Failure	<p>Water failure</p> <p>Suction problems</p>	<p><i>Pump failure is not necessarily the fault of the controller</i></p>
<p>RED LED</p> <p>LACK OF WATER</p> <p>Flashing</p>	<p>Pump not primed or has lost prime</p> <p>Water shortage. Valve on suction closed?</p> <p>Air leaks or pockets in the suction line</p> <p>Pump thermal protection activated</p> <p>Pump head less than cut in pressure</p>	
Display -P-	<p>The actual pressure in the pipe line has been more than 9.9 Bar for longer than 5 seconds</p>	<p>The controller may be damaged</p> <p>The pressure sensor may be damaged</p>
Display -A-	<p>Check for leaking taps, float valves, or check valves/foot valves</p>	<p>For the last 15 times the pump has run for less than 30 seconds.</p>



www.whiteint.com.au

www.whiteint.co.nz

Scan QR Code to save view other available documentation



Please always refer to our website for further technical information & new product innovations

Disclaimer: Every effort has been made to publish the correct information in this manual.
No responsibility will be taken for errors, omissions or changes in product specifications.

© 2020 Copyright White International Pty Ltd

TM ® - WARNING: Please be aware that various brands & products depicted within this document are subject to trademark, patent or design registrations. Infringement of any intellectual property contained within this document without express written authority by the appropriate intellectual property holder may result in further legal action to be taken. For any queries regarding use of the contained information please feel free to contact White International Pty Ltd.