

The pump is a self-priming surface mounted pressure system pump supplied with plug and play leads (IEC type). The self-priming ability provides excellent suction capacity of up to 9m. Used especially for supplying water to domestic applications

Model Number: ASC J50/100
Item Number: 809467

Pump Data	
Pressure Rating:	5.1 bar 510kPa
Min. fluid temp:	2° C
Max. fluid temp:	40° C
Max. operating temperature:	40° C

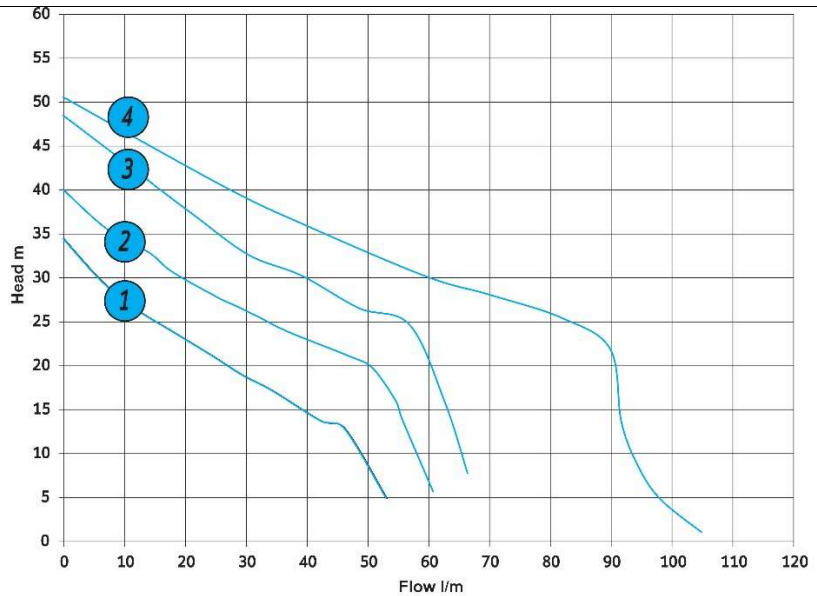

1 ASC-J35/50 2 ASC-J40/60 3 ASC-J48/65 4 ASC-J50/100

Max Flow Rate:	105LT/min
Max Head:	51m
Fluid:	Water, pure
Density:	998.3 kg/m ³

Materials	
Pump Body:	304 Stainless
Support:	Cast Aluminium
Motor Body:	Cast Aluminium
Mechanical Seal:	Carbon / Ceramic
Jet / Venturi:	Polypropylene
Impeller:	Polypropylene
O Ring:	Nitrile
Power Cable:	1.2m H05

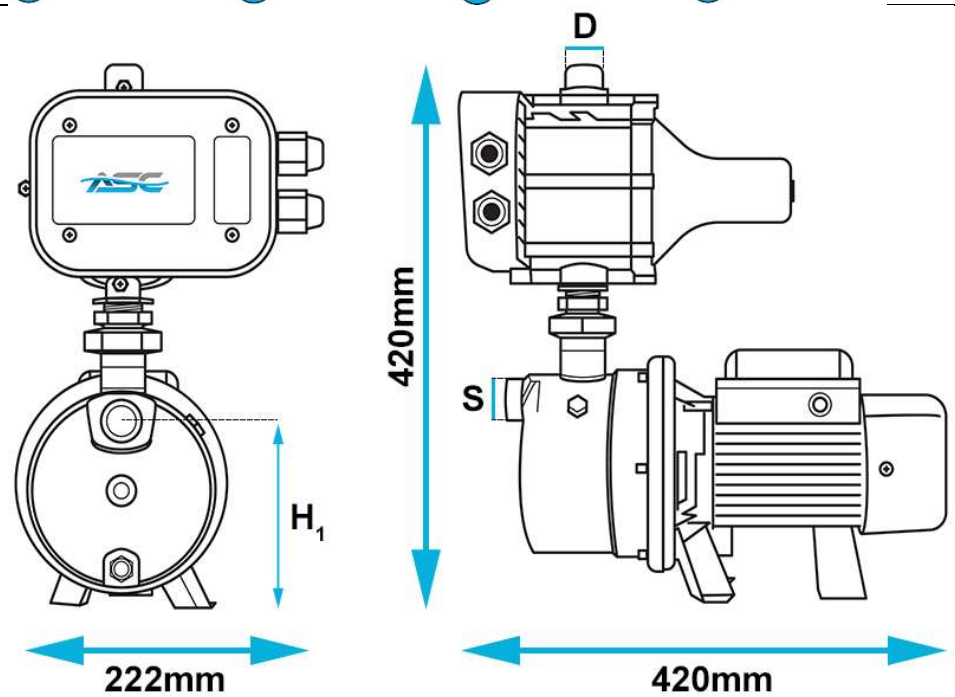

Electrical Data	
Phase:	Single Phase 1ϕ
Rated Voltage:	220-230V ~

Dimensions (mm)			
A (length)	420mm	S	40mm
B (width)	222mm	D	25mm
H (height)	420mm		
H ₁ (centre)	170mm		

Mains Frequency:	50Hz	Boxed Weight: Pump Weight:	16.10kg
P2 (kW):	1100W		18.14kg
HP:	1.5 hp		
Current:	4.78A		
Capacitor:	30μF		
VL:	450V		
Motor Duty:	Continuous		
Motor Type:	Asynchronous		
Ingress Protection:	TEFC		
Insulation Class:	IP X4		
Motor Protection:	B In-built thermal overload		

ASC Water Tanks reserves the right to make modifications without notice.