

The pump is a horizontal multistage surface mounted pressure system pump supplied with plug and play leads (IEC type) and a 2.2 bar cut in automatic restart pressure controller. The pump must be used for flooded suction application. Used especially for supplying water to domestic applications.

<b>Model Number:</b> ASC M60/120	
<b>Item Number:</b> 809469	
<b>Pump Data</b>	
Pressure Rating:	6.0 bar   600kPa
Min. fluid temp:	4° C
Max. fluid temp:	85° C
Max. operating temperature:	40° C

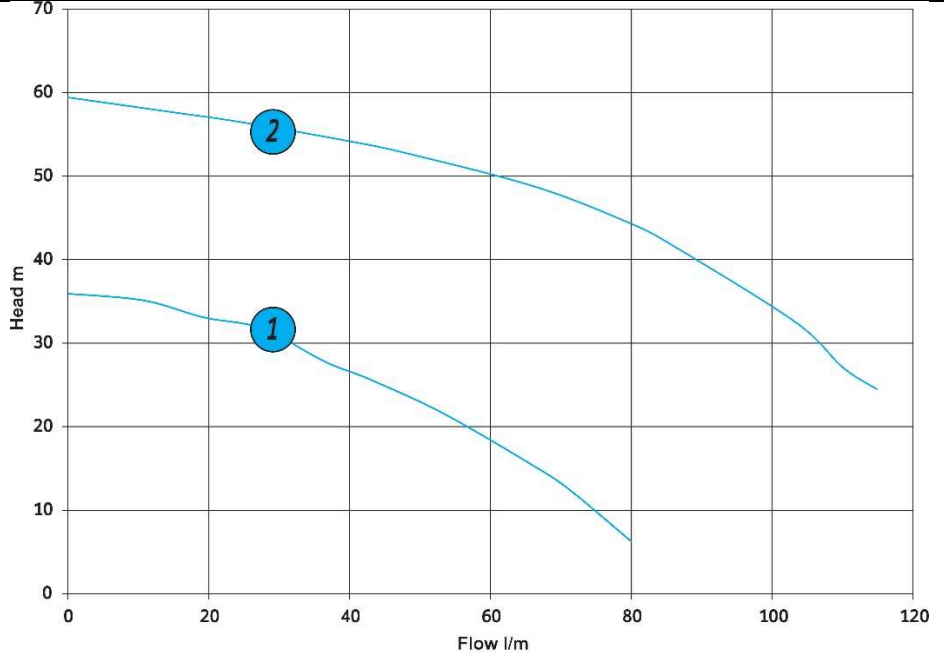

① ASC-M37/80      ② ASC-M60/120

Max Flow Rate:	115LT/min
Max Head:	60m
Fluid:	Water, pure
Density:	998.3 kg/m <sup>3</sup>

<b>Materials</b>	
Pump Body:	Stainless Steel
Support:	Cast Aluminium
Motor Body:	Cast Aluminium
Mechanical Seal:	Graphite / Silicon / Carbide
Impeller:	Stainless Steel
O Ring:	Nitrile
Power Cable:	1.2m H05

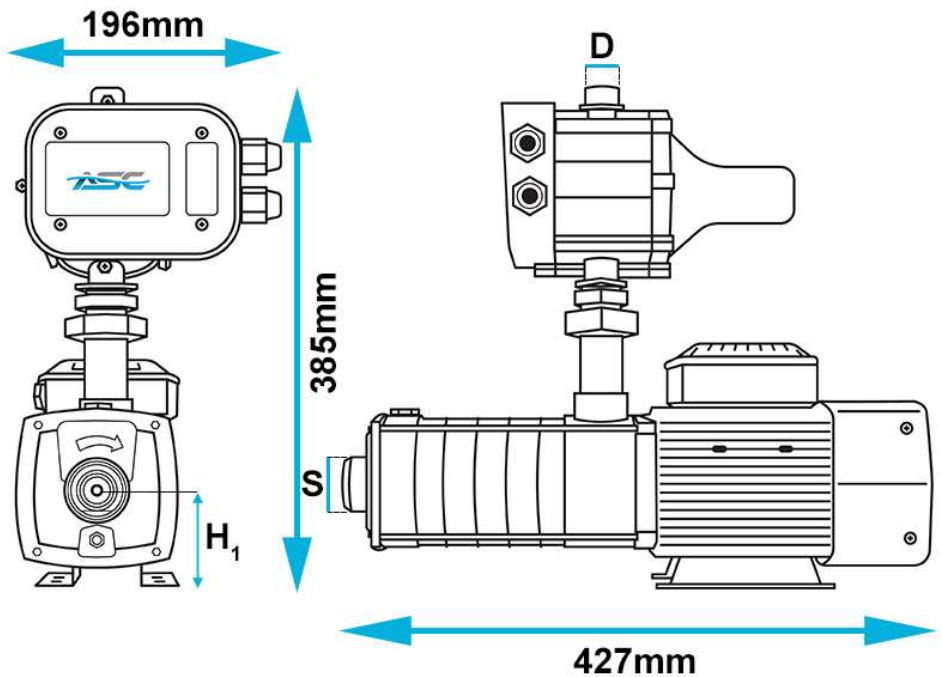

<b>Electrical Data</b>	
Phase:	Single Phase 1 $\phi$
Rated Voltage:	220-230V ~

<b>Dimensions (mm)</b>			
A (length)	427mm	S	32mm
B (width)	196mm	D	25mm
H (height)	385mm		
H <sub>1</sub> (centre)	93mm		

Mains Frequency:	50Hz	<b>Boxed Weight:</b> <b>Pump Weight:</b>	18.18kg 16.68kg
P2 (kW):	1300W		
HP:	1.5 hp		
Current:	5.65A		
Capacitor:	30μF		
VL:	450V		
Motor Duty:	Continuous		
Motor Type:	Asynchronous		
Ingress Protection:	TEFC		
Insulation Class:	IP X4		
Motor Protection:	B In-built thermal overload		

ASC Water Tanks reserves the right to make modifications without notice.