

The pump is an automatic water tank to mains switch pump that is used for operations to that require a mains water backup device. Suitable to pump to toilets, laundry, and garden taps. Jet pumps are suitable for applications where the water tank is below ground and are self-priming to a depth of 9m.

Model Number: ASC AJ60
Item Number: 802089

Pump Data	
Pressure Rating:	4.0 bar 400kPa
Min. fluid temp:	2° C
Max. fluid temp:	40° C
Max. operating temperature:	40° C

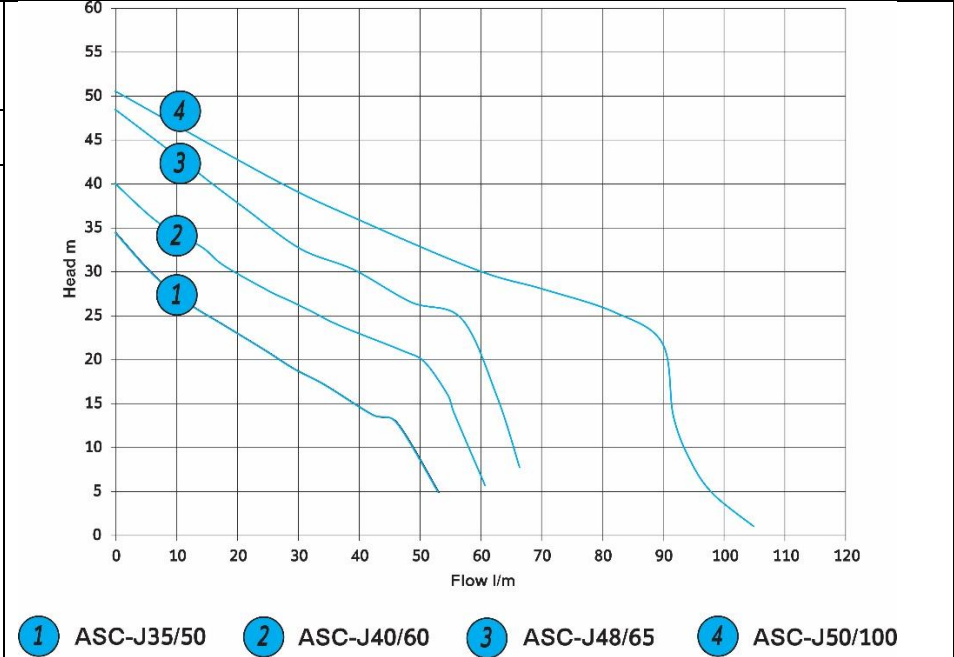

Max Flow Rate:	61LT/min
Max Head:	40m
Fluid:	Water, pure
Density:	998.3 kg/m ³

Pump Materials	
Pump Body:	304 Stainless
Support:	Cast Aluminium
Motor Body:	Cast Aluminium
Mechanical Seal:	Carbon / Ceramic
Jet / Venturi:	Polypropylene
Impeller:	Polypropylene
O Ring:	Nitrile
Power Cable:	1.2m H05

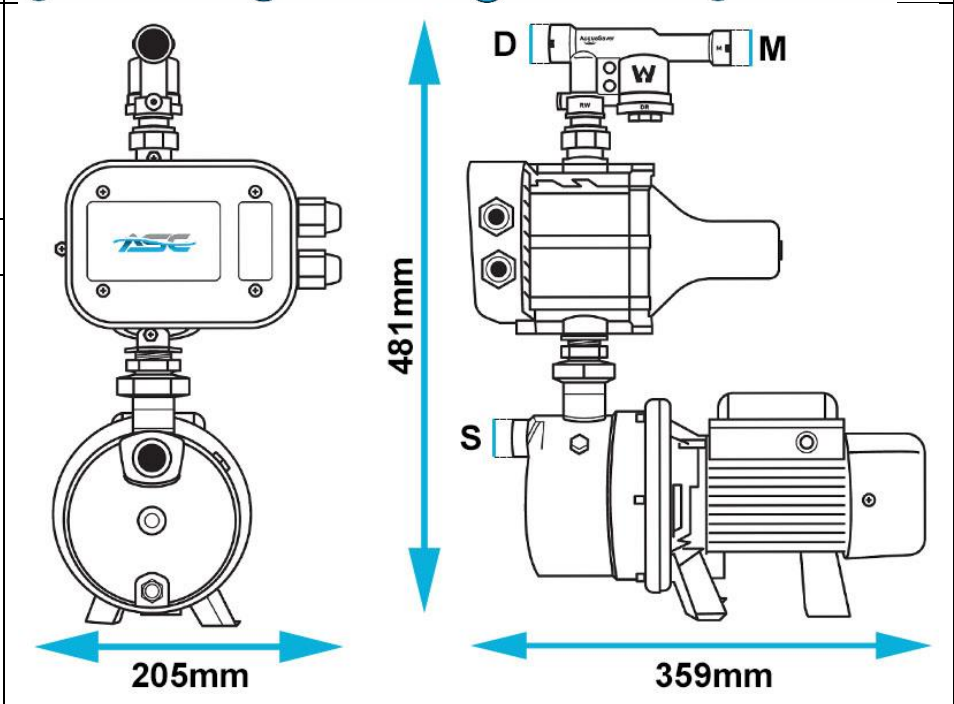

Electrical Data	
Phase:	Single Phase 1ø
Rated Voltage:	220-230V ~
Mains Frequency:	50Hz

Dimensions (mm)			
A (length)	359mm	S	25mm F
B (width)	205mm	D	20mm F
H (height)	481mm	M	20mm F
H ₁ (centre)	145mm		

P2 (kW):	550W	Boxed Weight: Pump Weight:	12.34kg
HP:	0.75 hp		12.34kg
Current:	2.39A		
Capacitor:	15µF		
VL:	450V		
Motor Duty:	Continuous		
Motor Type:	Asynchronous		
Ingress Protection:	TEFC		
Insulation Class:	IP X4		
Motor Protection:	B		
	In-built thermal overload		

Acquasaver Data

Max Mains:	500kPa	
Min Pump:	300kPa	
Max Pump:	600kPa	
Pump Cut In:	2 Bar	
Max Flow Rate:	50LT/min	
Max Water Temp:	40°C	
Min Water Temp:	0°C*	
Pump Inlet:	25mm 1" BSP F	
Mains Water In:	20mm ¾" BSP F	
Outlet:	20mm ¾" BSP F	
Weight:	2.5kg	

Shown with optional wall bracket. Not Standard Inclusion.

ASC Water Tanks reserves the right to make modifications without notice.