

Installation/ mounting and maintenance instructions for SAPHIR universal shaft 600/ 900/ 1200/ 1500 I

600 I	Order no. 12.1101
900 I	Order no. 12.1102
1200 I	Order no. 12.1103
1500 I	Order no. 12.1119



The points described in these instructions must be observed in all cases. Failure to do so shall invalidate the warranty. For any additional Garantia branded items, you will receive separate installation instructions in the transport packaging.

The components must be checked for any damage before the system is transferred to the pit.

You can request any missing instructions from info@garantia.net.au

Contents	
1. GENERAL INFORMATION	2
1.1 Safety	2
2. TRANSPORT, STORAGE AND UNLOADING	3
2.1 Transport	3
2.2 Storage	3
2.3 Unloading	3
3. INSTALLATION CONDITIONS	4
4. TECHNICAL DATA	5
5. STRUCTURE OF SHAFT	8
6. INSTALLATION AND ASSEMBLY	8
6.1 Foundation	9
6.2 Trench	9
7. ASSEMBLY OF TELESCOPIC DOME SHAFT	12
7.1 Fitting the telescopic dome shaft	12
7.2 Telescopic dome shaft for pedestrian loading	12
7.3 Telescopic dome shaft for vehicle loading	12
7.4 Telescopic dome shaft for HGV loading	12
8. ASSEMBLY OF SPACER	13
8.1 Fitting the Extension Sleeve	13
9. INSPECTION AND MAINTENANCE	13

1. General information

1.1 Safety

All work should be undertaken in compliance with the relevant accident prevention regulations according to BGV C22. A second person is required for safety reasons, particularly when inspecting the shaft.

In addition, the applicable regulations and standards must be respected during installation, assembly, maintenance, repairs etc. Relevant information can be found in the corresponding sections of these instructions.

The entire system must always be switched off and secured against unauthorised resetting during any work on the system or system components.

The shaft cover must always be kept closed, except during work on the shaft, otherwise the risk of accidents is high. The fit of the cover should be regularly checked. Only original Garantia parts are to be used.

Garantia provides an extensive range of accessories, which are all coordinated and can be combined to form complete systems. The use of other accessories may result in restrictions of the system's functionality and to liability being revoked for damage incurred.

2. Transport, storage and unloading

2.1 Transport

The universal shaft components must be secured to prevent shifting and falling during transport. If the components are secured for transport using tension belts, make sure that they remain undamaged.

Stress caused by impacts must be avoided at all costs. Shafts must in no event be rolled or dragged across the ground.

2.2 Storage

If the shafts require intermediate storage, this must be done on suitable level ground. During storage, damage caused by environmental or external factors must be avoided.

2.3 Unloading

The shaft can be unloaded using the two factory-fitted lifting eyes (M8 eye bolts) on the upper side of the shaft to the left and right of the access dome (see Fig.).

Please note: The shaft must only be unloaded when empty and should be unloaded as quickly as possible to avoid placing excessive strain on the lifting eyes.

Under no circumstances should anyone stand underneath the suspended load!

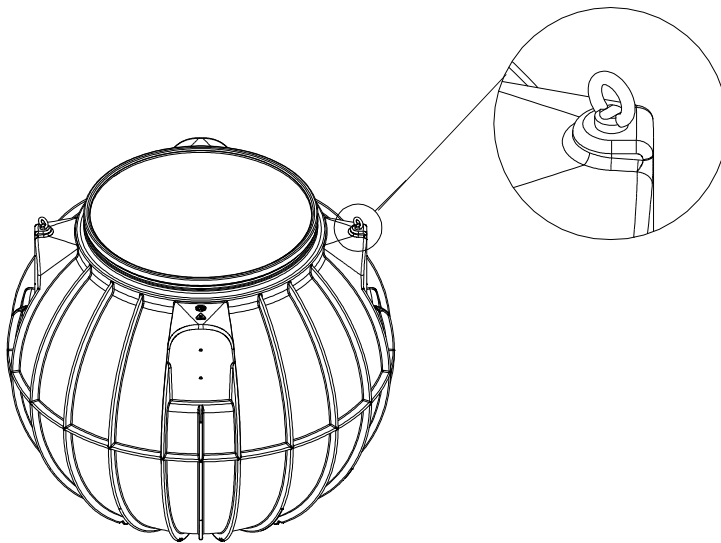

3. Installation conditions

Cover heights with telescopic dome shaft (Mini / Maxi) in green area.

Mini telescopic dome shaft

Maxi / cast telescopic dome shaft

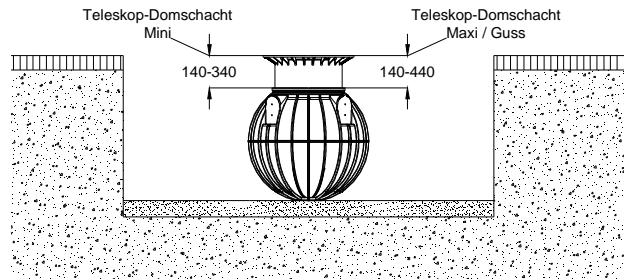

Cover heights with extension sleeve and telescopic dome shaft, maximum.

(For use **In green areas only** – not suitable for trafficked areas.)

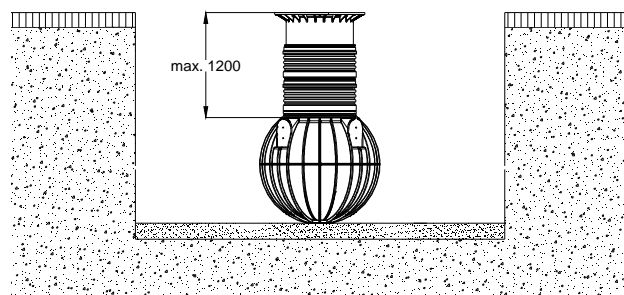

Cover heights with cast iron telescopic dome shaft (class B) in area driven over by vehicles up to 3.5 tonnes without groundwater or standing groundwater, see also 7.3.

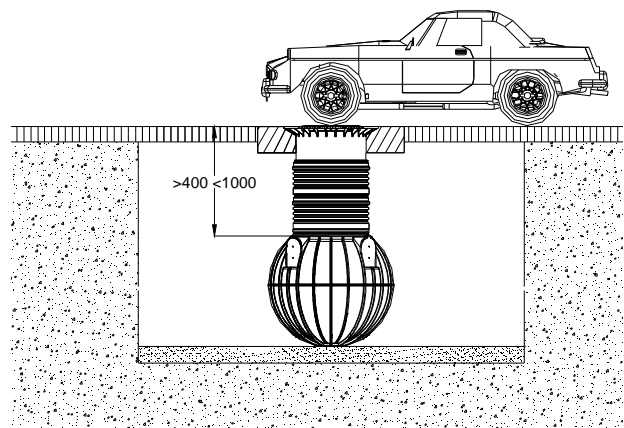

Cover heights with cast or HGV-bearing telescopic dome shaft

(with cover class B or D – provided by customer), in area driven over by HGVs – without groundwater or standing groundwater, see also 6.2.3. and 7.4.

Please note: HGV can only be driven over if a self-supporting, (Steel)-reinforced concrete bridge is installed.

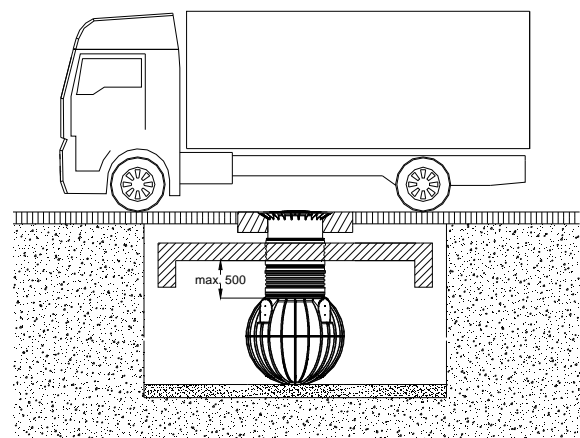

Cover heights for installation in groundwater - the hatched area shows the permissible submersion depth of the shaft, see also 6.2.2.

(For use **In green areas only** – not suitable for trafficked areas.)

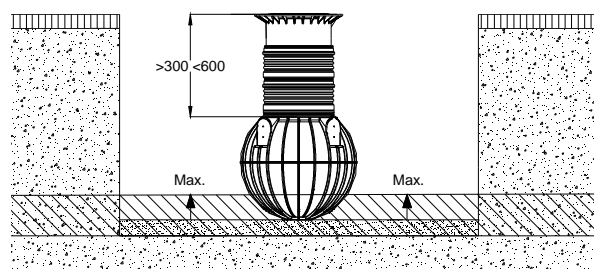

4. Technical data

600 I:

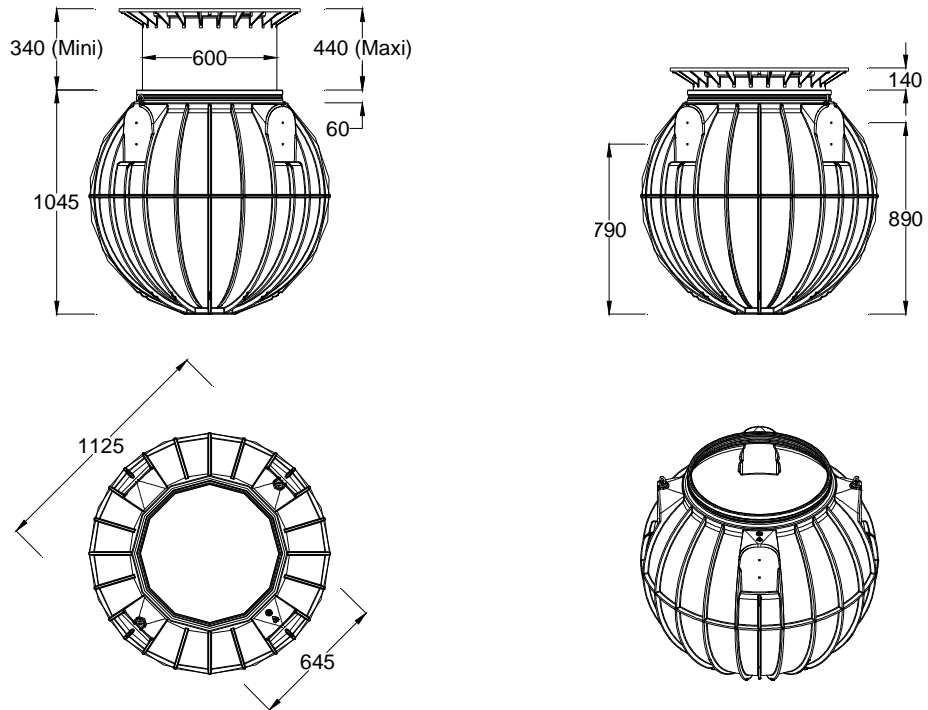

900 I:

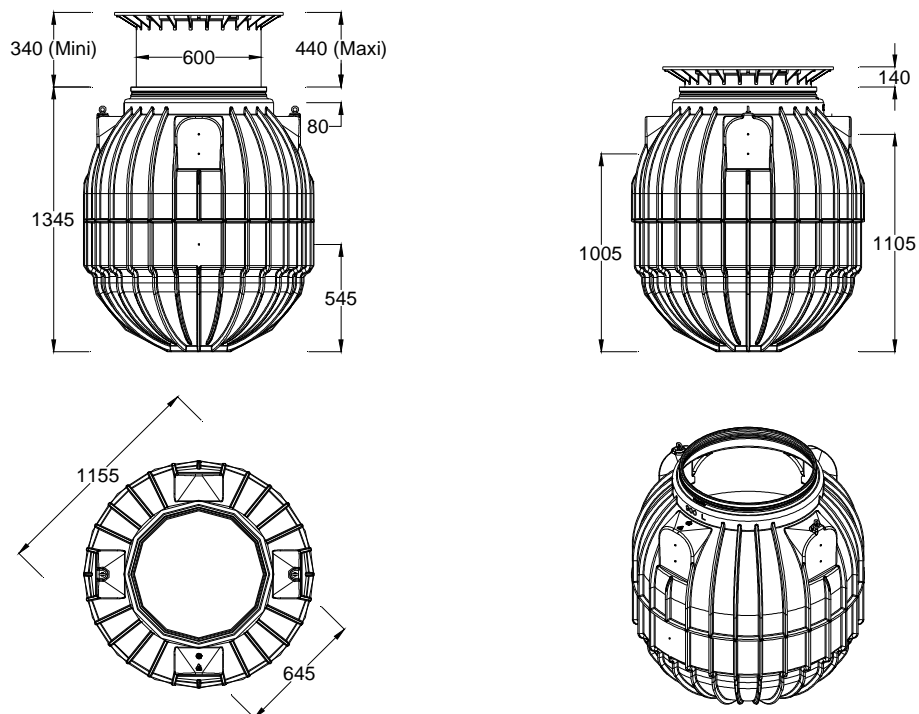

4. Technical data

1200 l:

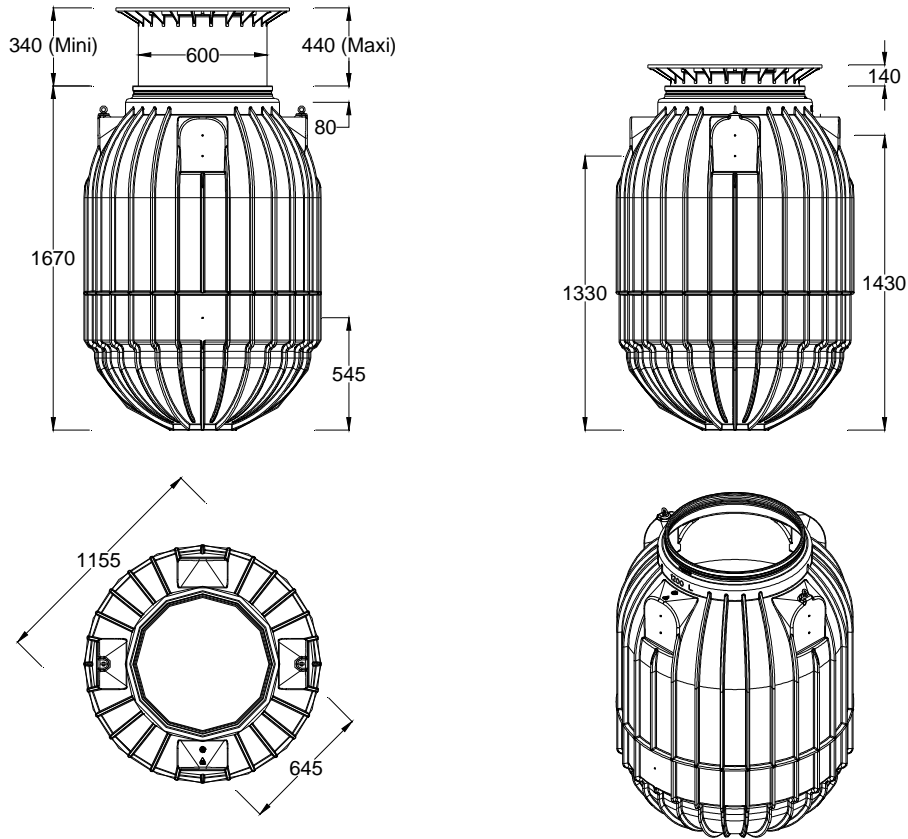

1500 l:

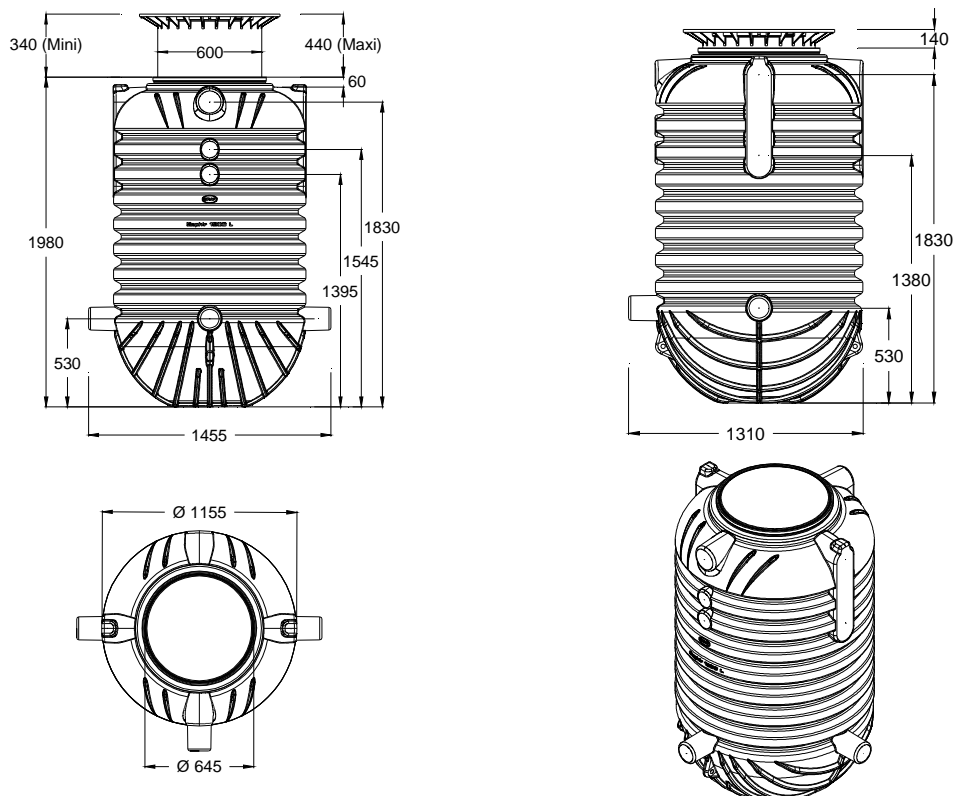

4. Technical data

Shaft	600 l	900 l	1200 l	1500 l
Art. no.	12.1101	12.1102	12.1103	12.1119
Weight	27 kg	47 kg	58 kg	110 kg
L	Diameter 1125 mm	Diameter 1155 mm	Diameter 1155 mm	Diameter 1310 mm
W	Diameter 1125 mm	Diameter 1155 mm	Diameter 1155 mm	Diameter 1455 mm
H	1045 mm	1345 mm	1670 mm	1980 mm

5. Structure of shaft

- ① Telescopic dome shaft PE cover
- ② Telescopic dome shaft (tilts by 5°)
- ③ Profile seal
- ④ SAPHIR universal shaft

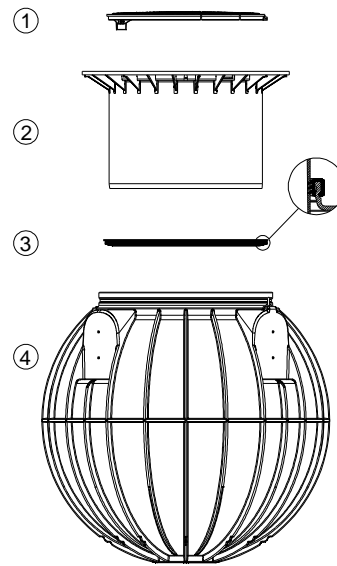

6. Installation and assembly

- ① Soil
- ② Telescopic dome shaft
- ③ Compacted base layer
- ④ Surround (round gravel, max. grain 8 to 16mm)
- ⑤ Covering layer
- ⑥ SAPHIR universal shaft
- ⑦ Concrete layer for trafficked areas
- ⑧ It is especially important for the gravel surround around the bottom third of the shaft to be well compacted

β --> DIN 4124 as of trench depth of 1250 mm

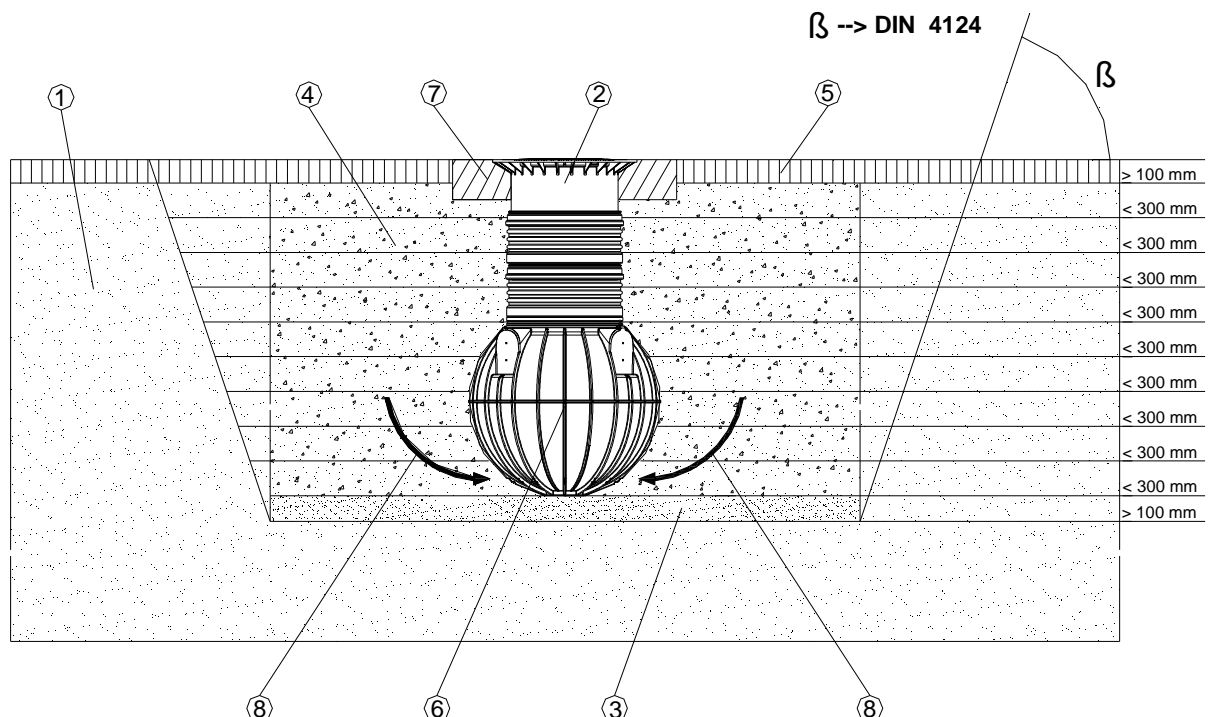

6. Installation and assembly

6.1 Foundation

The following criteria must be verified prior to installation:

- The structural suitability of the soil in accordance with DIN 18196
- Maximum groundwater levels / drainage of the subsoil
- Types of loading present, e.g. traffic load

Please note: HGV can only be driven over if a self-supporting, steel-reinforced concrete bridge is installed!

A soil survey should be requested from the local building authority to determine the physical properties of the soil.

6.2 Trench

To ensure that sufficient working space is available, the base area of the trench must exceed the shaft dimensions by over 300 mm on all sides. The distance from fixed structures must be at least 1000 mm.

Please note: If the trench depth is greater than 1250 mm, an embankment should be built in accordance with DIN 4124. The foundation must be horizontal and even and must offer sufficient load-bearing capacity.

The trench must be deep enough that the maximum earth cover above the shaft (see 3 - Installation conditions) is not exceeded. For the system to be usable all year round, the shaft and water-carrying parts must be installed in a frost-free zone. The frost-free depth is usually around 600 mm - 800 mm; for accurate information, please contact the responsible authority.

The substructure is made from a layer of compacted round gravel (grain 8/16, approx. 100 mm - 150 mm thick).

6.2.1 Positioning on a slope, embankment etc.

If the shaft is installed in immediate proximity (less than 5 m) to a slope, mound or embankment, a statically calculated supporting wall must be constructed to bear the pressure of the soil. The wall must exceed the shaft dimensions by at least 500 mm in all directions and must be at least 1000 mm away from the shaft.

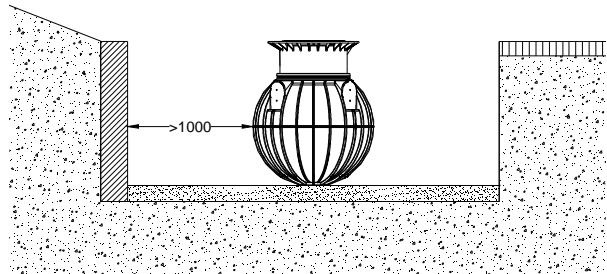

6.2.2 Groundwater and cohesive (non-water-permeable) soils (e.g. loam)

If it is likely that the shafts will be submerged deeper in groundwater than indicated in the table below, sufficient drainage must be provided (for max. submersion depths and required earth cover, see table). In cohesive, non-water-permeable soils we recommend installing drainage (e.g. ring drainage) for seepage water (**not below driven-on surfaces**).

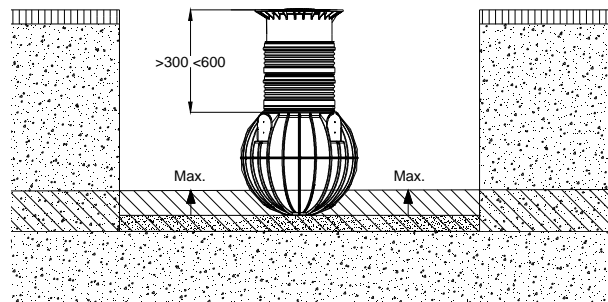

SAPHIR universal shaft	600 l	900 l	1200 l	1500 l
Max. submersion depth	430 mm	430 mm	550 mm	550 mm
Required earth cover (mm)	min. 300 – max. 600	min. 300 – max. 600	min. 300 – max. 600	min. 300 – max. 600

6. Installation and assembly

6.2.3 Installation below HGV-bearing surfaces

The shaft can only be driven over with HGV in conjunction with a self-supporting, iron-reinforced concrete bridge. To ensure that no additional forces or effects of HGV-bearing are transferred to the shafts, the dimensions and strength of the concrete bridge must be statically calculated.

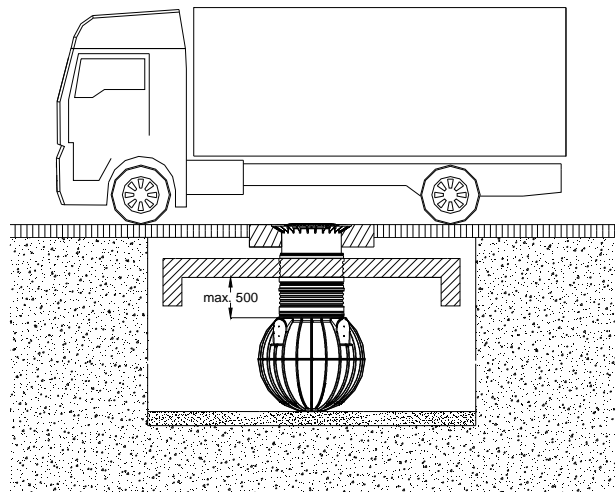

6.2.4 Installation next to driven-on surfaces

If the shafts are installed next to roadways used by heavy vehicles weighing over 3,5 t, the minimum distance from these surfaces must be at least the depth of the trench.

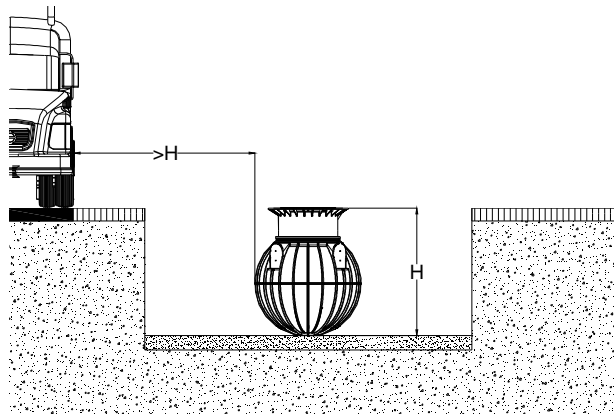

6.2.5 Connecting multiple shafts

Two or more shafts can be connected by means of drilling a hole in each tank and installing, Garantia special seals and 110mm underground pipe (provided by the customer).

The openings must only be drilled with the Garantia special core drill and to the appropriate size. Ensure that the distance between the shafts is at least 500 mm. The pipes must extend at least 200 mm into the shafts.

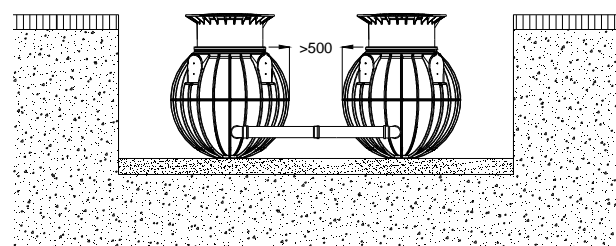

6. Installation and assembly

6.2.6 Insertion and filling

The shafts should be carefully lowered into the excavation avoiding any sudden jolts.

The shaft must be filled 1/3 full of water before commencing the back filling. The back fill should be carried out using 8 to 16mm single sized gravel and compacted in 30cm (max.) layers until the top of the shaft is reached.

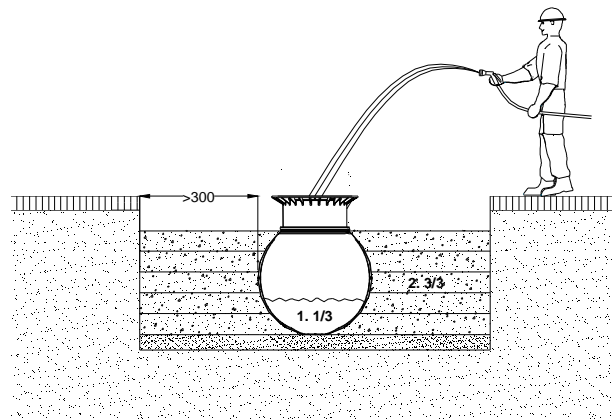

The individual layers and the lower zone of the shafts must be well compacted (with a hand tamper). Be careful to avoid damaging the shafts when compacting the gravel. Mechanical compression machines must never be used. The trench surround must be at least 300 mm wide.

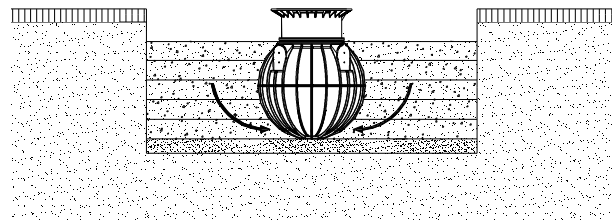

Please note: It is especially important for the filling in the bottom third of the shaft to be well compacted

7. Assembly of telescopic dome shaft

7.1 Fitting the telescopic dome shaft

The telescopic dome shaft allows the shaft to be smoothly adjusted to the terrain surface between an earth cover of 140 mm and 340 mm (Mini telescopic dome shaft) or 140 mm and 440 mm (Maxi telescopic dome shaft). To assemble, the profile seal (material EPDM) of the shaft dome is rubbed in with plenty of soft soap (do not use lubricants with a mineral oil base because they will corrode the seal). The telescopic dome shaft is then greased, slid in and aligned to the terrain surface.

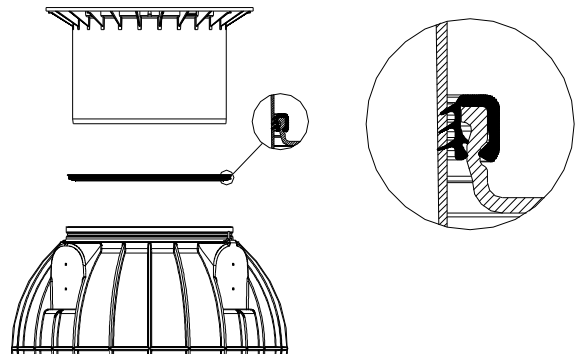

7.2 Telescopic dome shaft for pedestrian loading

Important: To prevent loads from being transferred to the shaft, the telescopic dome shaft is filled ① in layers with round gravel ② (max. grain 8/16) and evenly compressed. Avoid damaging the shaft dome ③ and telescope. Then fit the cover and lock it with the childproof lock, **tightening the screw on the cover sufficiently such that it cannot be opened by a child.**

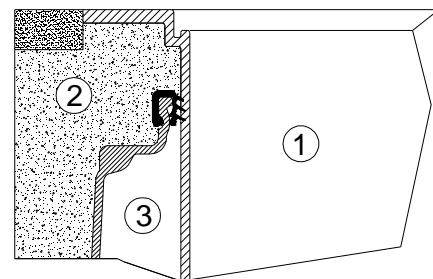

7.3 Telescopic dome shaft for vehicle loading

If the shaft is installed below a surface driven on by vehicles, the telescopic dome shaft ① (colour anthracite) must be lined with concrete in the collar area ④ (load class B25 = 250 kg/m²). The concrete layer must be at least 300 mm wide and approx. 200 mm high all the way round. To extend the shaft, the cast iron telescopic dome shaft (max. useful length 440 mm) and the extension sleeve (max. useful length 300 mm) can be used.

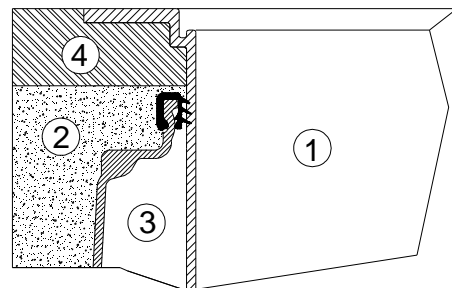

Attention: Use the cast cover under all circumstances.

7.4 Telescopic dome shaft for HGV loading

When installing below surfaces driven on by HGVs, the telescope is lined ① as described in 7.3. The concrete rings ⑥ (diameter 600 mm) and a cast frame ⑤ with star-shaped load distribution are then installed to support the cast cover. The cast frame must have a contact area of approx. 1 m². To extend the shaft, the telescopic dome shaft for HGV loading with class D cover, provided by the customer (max. useful length 440 mm), and the spacer (max. useful length 300 mm) can be used.

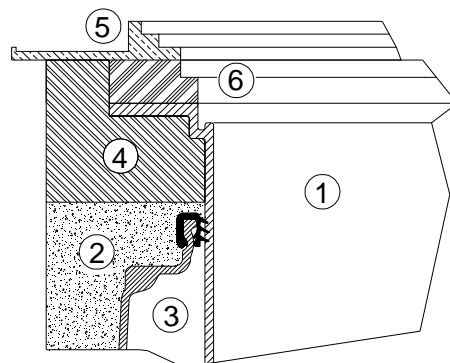

Please note: Can only be driven over with HGV, if a self-supporting, steel-reinforced concrete bridge is installed.

8. Assembly of spacer

8.1 Fitting the Extension Sleeve

If a spacer is needed for larger earth covers it is inserted into the shaft dome with the aid of soft soap. The profile seal is fitted in the topmost groove of the extension sleeve and greased with plenty of lubricant. Then slide the telescopic dome shaft into place and adjust to suit the planned terrain surface.

1 extension sleeve = max. earth cover 640 mm / 740 mm
(in conjunction with the Mini / Maxi telescopic dome shaft)

- ① Telescopic dome shaft (tilts by 5°)
- ② Spacer
- ③ Profile seal
- ④ SAPHIR universal shaft

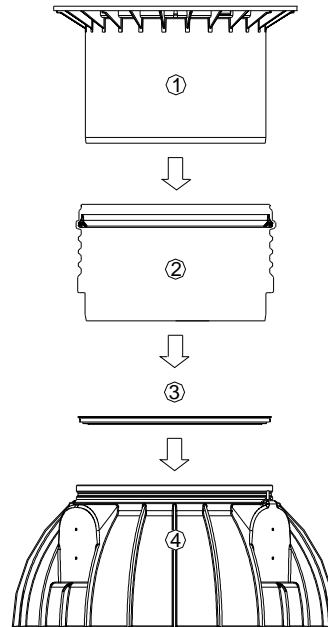

9. Inspection and maintenance

The entire system must be checked for tightness, cleanliness and stability at least once every three months.

The entire system should be maintained approximately every 5 years. All parts should be cleaned and their function checked. For maintenance, proceed as follows:

- Fully empty shaft
- Clean surfaces and built-in parts with water
- Remove all dirt and contamination from the shaft
- Check that all built-in parts are securely mounted

Please note: During every maintenance the outlet must be checked and flushed if necessary.