

Qty. Description

1 UPS 25-80 N 180



Note! Product picture may differ from actual product

Product No.: [95906439](#)

The pump is of the canned rotor type, i.e. pump and motor form an integral unit without shaft seal and with only two gaskets for sealing.

The bearings are lubricated by the pumped liquid.

The pump has 3-step speed selector.

The pump is characterized by:

- * Ceramic shaft and radial bearings.
- * Carbon axial bearing.
- * Stainless steel rotor can and bearing plate.
- * Corrosion-resistant impeller, Composite.
- * Stainless steel pump housing.

The motor is a 1-phase motor.

No additional motor protection is required.

Liquid:

Pumped liquid: Water
 Liquid temperature range: -25 .. 110 °C
 Selected liquid temperature: 60 °C
 Density: 983.2 kg/m³

Technical:

Rated flow: 4.95 m³/h
 Rated head: 4.56 m
 TF class: 110
 Approvals: CE,EAC,WEEE,RCM

Materials:

Pump housing: Stainless steel
 EN 1.4308
 AISI 304
 Impeller: Composite
 PES+30% GF

Installation:

Range of ambient temperature: 0 .. 40 °C
 Amb. max at 80 dgr C liquid: 40 °C
 Maximum operating pressure: 10 bar
 Type of connection: G
 Size of connection: 1 1/2 inch
 Pressure rating for connection: PN 10
 Port-to-port length: 180 mm

Electrical data:

Power input in speed 1: 110 W



Company name: ASC Water Tanks
Created by: Anant Yuvarajah
Phone: 03 8795 7715
Email: sales@asc tanks.com.au
Date: 13/06/2024

Qty. Description

1	Power input in speed 2:	155 W
	Max. power input:	165 W
	Mains frequency:	50 Hz
	Rated voltage:	1 x 230 V
	Current in speed 1:	0.5 A
	Current in speed 2:	0.7 A
	Current in speed 3:	0.7 A
	Capacitor size - run:	4 µF
	Enclosure class (IEC 34-5):	X2D
	Insulation class (IEC 85):	F
	Built-in motor protection:	CONTACT
	Others:	
	Terminal box position:	9H
	Net weight:	4.65 kg
	Gross weight:	4.93 kg
	Shipping volume:	0.008 m ³
	Danish VVS No.:	380633100
	Swedish RSK No.:	5803099
	Finnish LVI No.:	4615614
	Norwegian NRF no.:	9042217
	Country of origin:	RS
	Custom tariff no.:	84137090622081967



Company name: ASC Water Tanks
Created by: Anant Yuvarajah
Phone: 03 8795 7715
Email: sales@asc tanks.com.au
Date: 13/06/2024

95906439 UPS 25-80 N 180 50 Hz

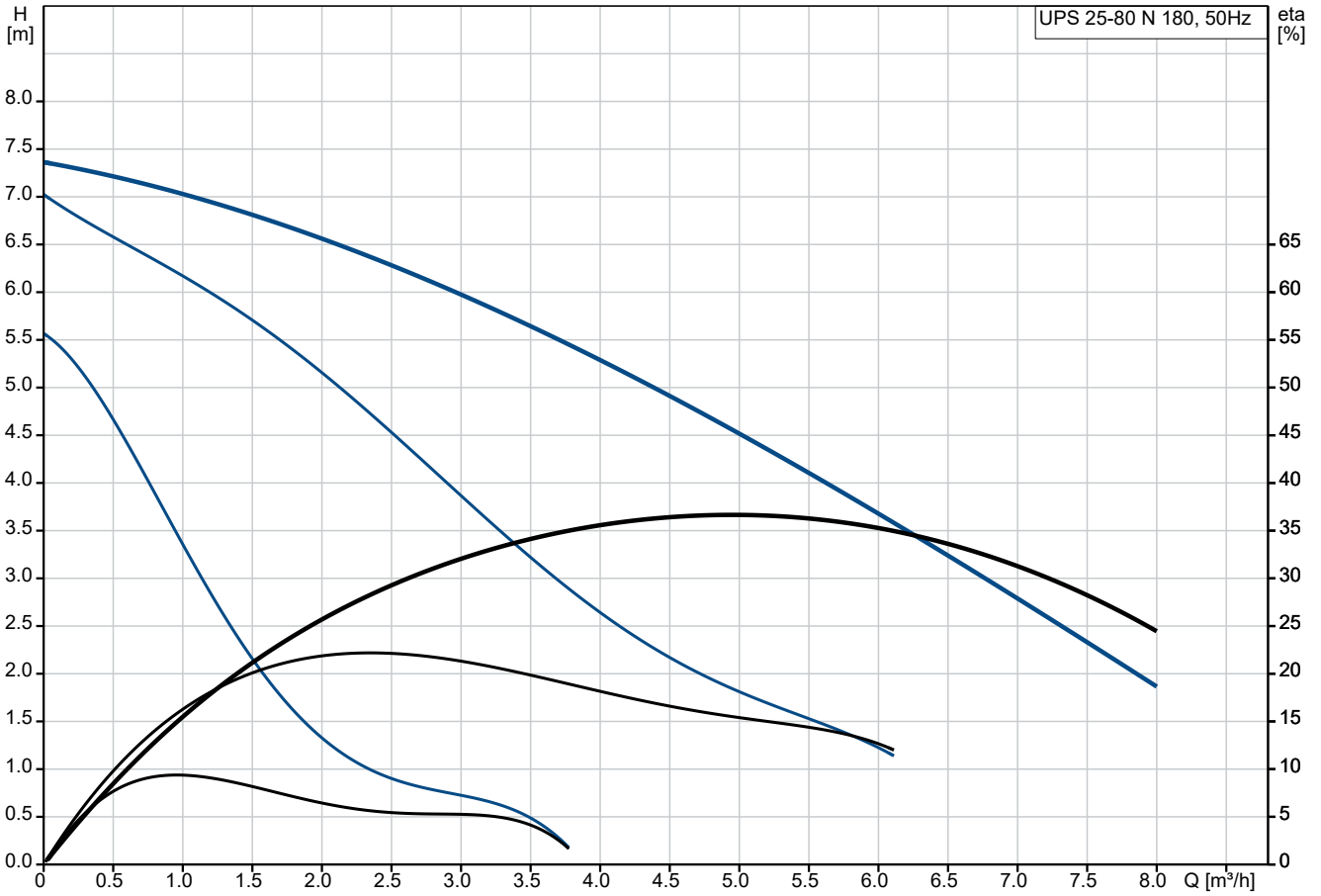

Pumped liquid = Water
Liquid temperature during operation = 60 °C
Density = 983.2 kg/m³

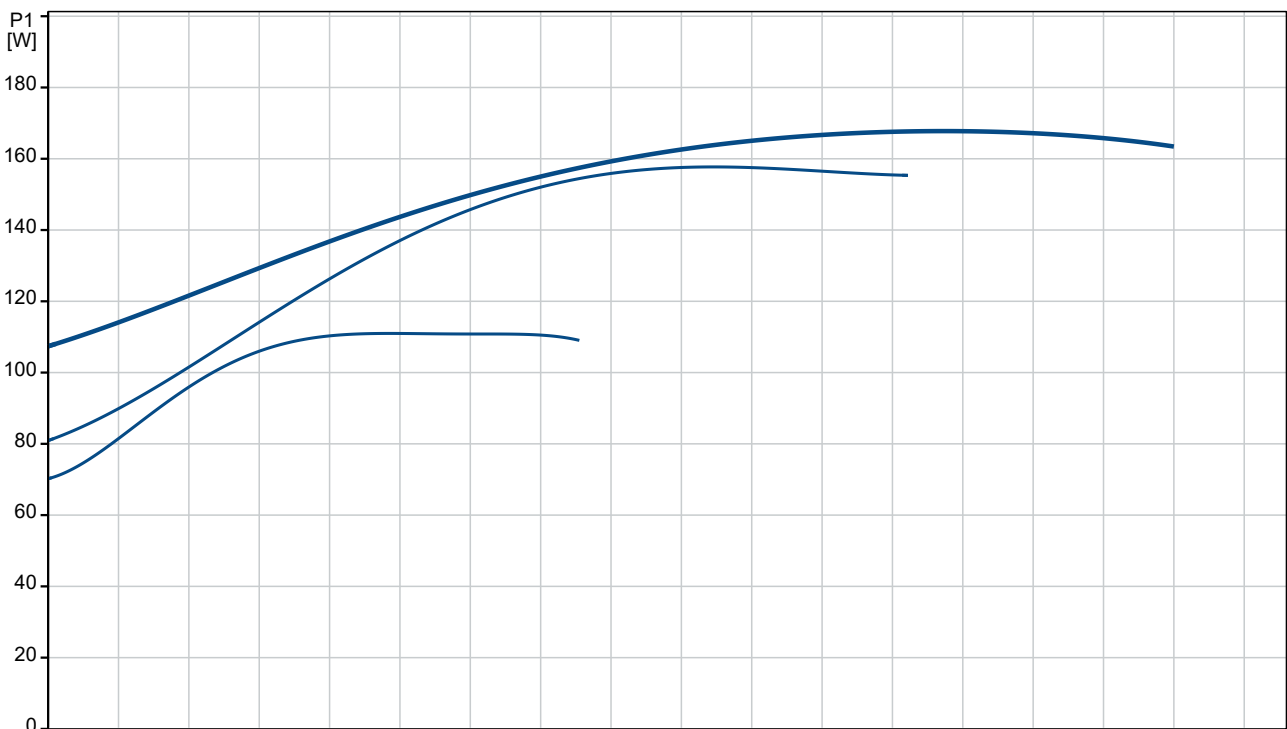

Description	Value
General information:	
Product name:	UPS 25-80 N 180
Product No:	95906439
EAN number:	5700310346588
Price:	AUD 1383
Technical:	
Speed no:	3
Rated flow:	4.95 m ³ /h
Rated head:	4.56 m
Maximum head:	80 dm
TF class:	110
Approvals:	CE,EAC,WEEE,RCM
Materials:	
Pump housing:	Stainless steel
Pump housing:	EN 1.4308
Pump housing:	AISI 304
Impeller:	Composite
Impeller:	PES+30% GF
Installation:	
Range of ambient temperature:	0 .. 40 °C
Amb. max at 80 dgr C liquid:	40 °C
Maximum operating pressure:	10 bar
Type of connection:	G
Size of connection:	1 1/2 inch
Pressure rating for connection:	PN 10
Port-to-port length:	180 mm
Liquid:	
Pumped liquid:	Water
Liquid temperature range:	-25 .. 110 °C
Selected liquid temperature:	60 °C
Density:	983.2 kg/m ³
Electrical data:	
Power input in speed 1:	110 W
Power input in speed 2:	155 W
Max. power input:	165 W
Mains frequency:	50 Hz
Rated voltage:	1 x 230 V
Current in speed 1:	0.5 A
Current in speed 2:	0.7 A
Current in speed 3:	0.7 A
Capacitor size - run:	4 µF
Enclosure class (IEC 34-5):	X2D
Insulation class (IEC 85):	F
Built-in motor protection:	CONTACT
Thermal protec:	INT.
Others:	
Terminal box position:	9H
Net weight:	4.65 kg
Gross weight:	4.93 kg
Shipping volume:	0.008 m ³
Danish VVS No.:	380633100
Swedish RSK No.:	5803099
Finnish LVI No.:	4615614
Norwegian NRF no.:	9042217
Country of origin:	RS
Custom tariff no.:	84137090622081967

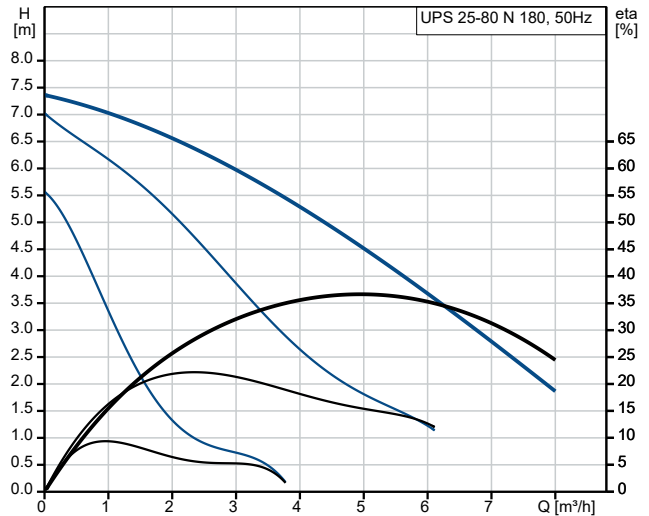

Pumped liquid = Water
 Liquid temperature during operation = 60 °C
 Density = 983.2 kg/m³

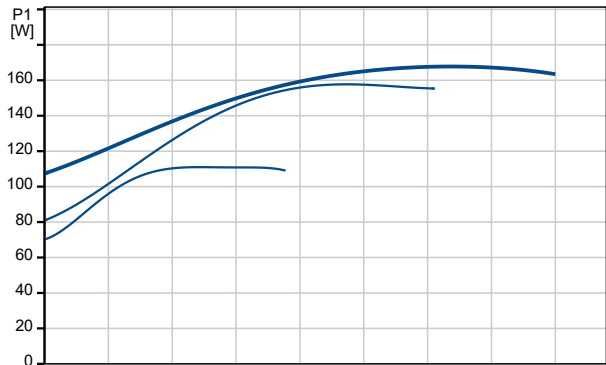

95906439 UPS 25-80 N 180 50 Hz

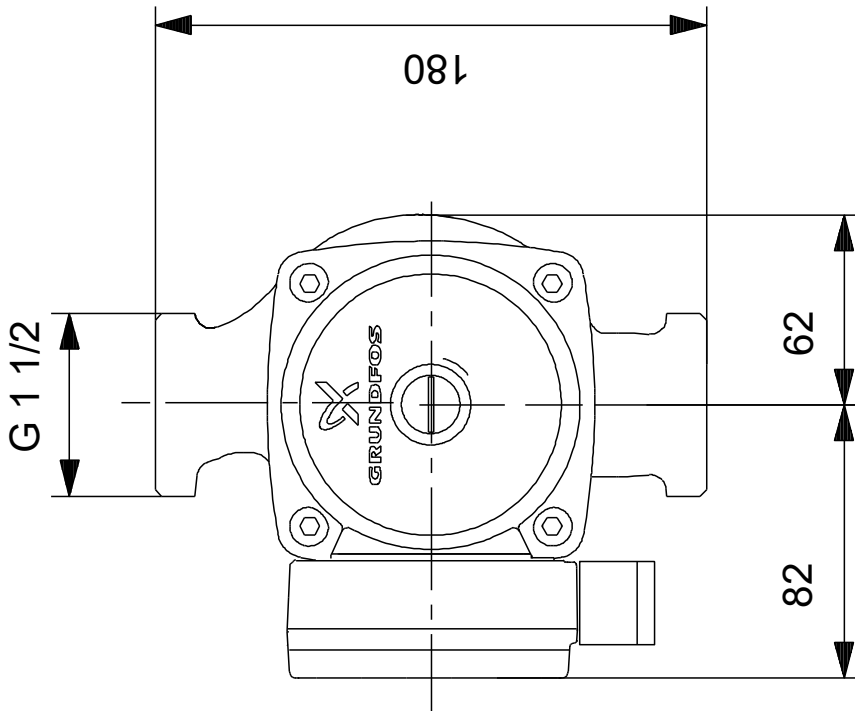
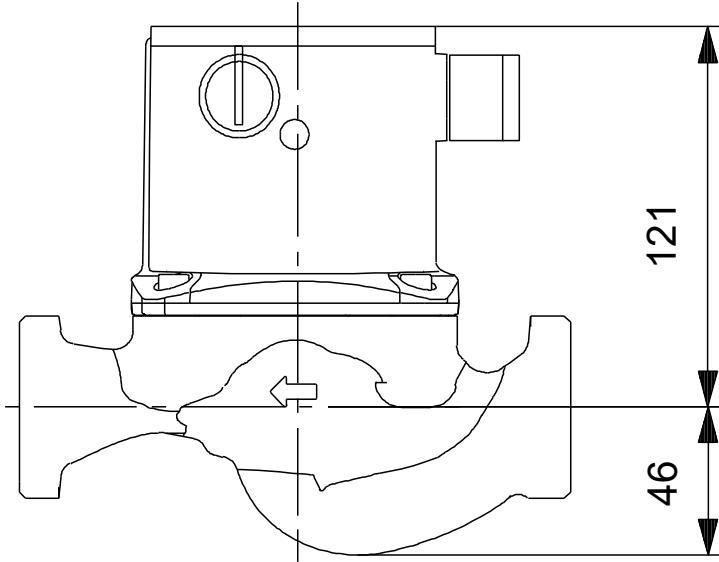

Note! All units are in [mm] unless others are stated.
Disclaimer: This simplified dimensional drawing does not show all details.