

Qty. Description

1 UPS 25-60 130



Note! Product picture may differ from actual product

Product No.: [96281476](#)

The pump is of the canned rotor type, i.e. pump and motor form an integral unit without shaft seal and with only two gaskets for sealing. The bearings are lubricated by the pumped liquid. The pump has 3-step speed selector. The pump is characterized by:

- * Ceramic shaft and radial bearings.
- * Carbon axial bearing.
- * Stainless steel rotor can and bearing plate.
- * Corrosion-resistant impeller, Composite.
- * Cast iron pump housing.

The motor is a 1-phase motor.
No additional motor protection is required.

Liquid:
 Pumped liquid: Water
 Liquid temperature range: 2 .. 110 °C
 Selected liquid temperature: 60 °C
 Density: 983.2 kg/m³

Technical:
 Rated flow: 1.9 m³/h
 Rated head: 3.109 m
 TF class: 110
 Approvals: VDE,EAC,RCM

Materials:
 Pump housing: Cast iron
 EN 1561 EN-GJL-150
 ASTM 30 B
 Impeller: Composite
 PES+30% GF

Installation:
 Range of ambient temperature: 0 .. 40 °C
 Maximum operating pressure: 10 bar
 Type of connection: G
 Size of connection: 1 1/2 inch
 Pressure rating for connection: PN 10
 Port-to-port length: 130 mm

Electrical data:
 Power input in speed 1: 50 W
 Power input in speed 2: 60 W



Company name: ASC Water Tanks
Created by: Anant Yuvarajah
Phone: 03 8795 7715
Email: sales@asc tanks.com.au
Date: 12/06/2024

Qty. Description

1	Max. power input:	70 W
	Mains frequency:	50 Hz
	Rated voltage:	1 x 230 V
	Current in speed 1:	0.22 A
	Current in speed 2:	0.27 A
	Current in speed 3:	0.3 A
	Capacitor size - run:	2.5 µF
	Enclosure class (IEC 34-5):	IP44
	Insulation class (IEC 85):	F
	Built-in motor protection:	NONE
	Others:	
	Terminal box position:	9H
	Net weight:	2.4 kg
	Gross weight:	2.54 kg
	Shipping volume:	0.004 m ³
	Country of origin:	DK
	Custom tariff no.:	84137090622081967

96281476 UPS 25-60 130 50 Hz

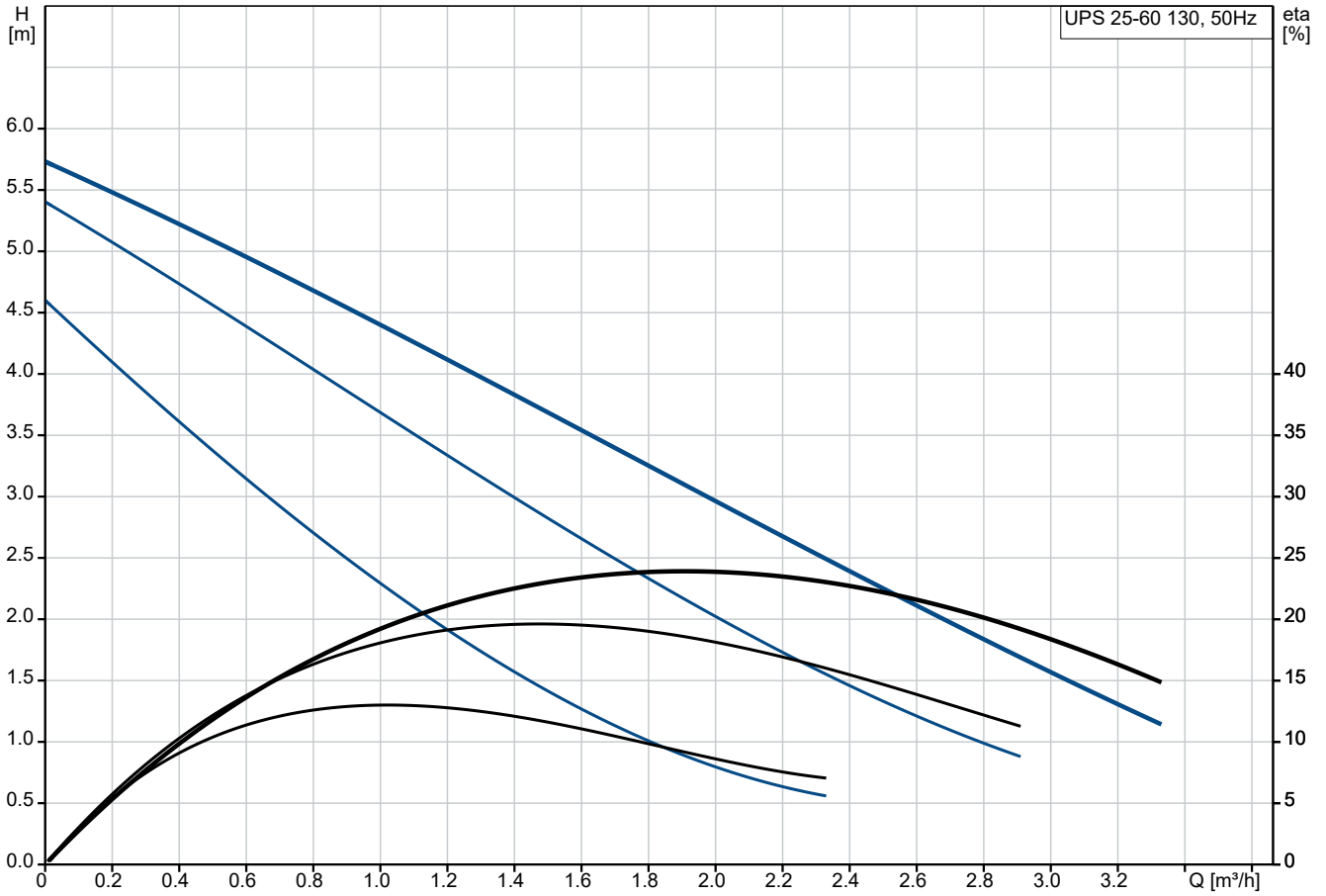

Pumped liquid = Water
 Liquid temperature during operation = 60 °C
 Density = 983.2 kg/m³

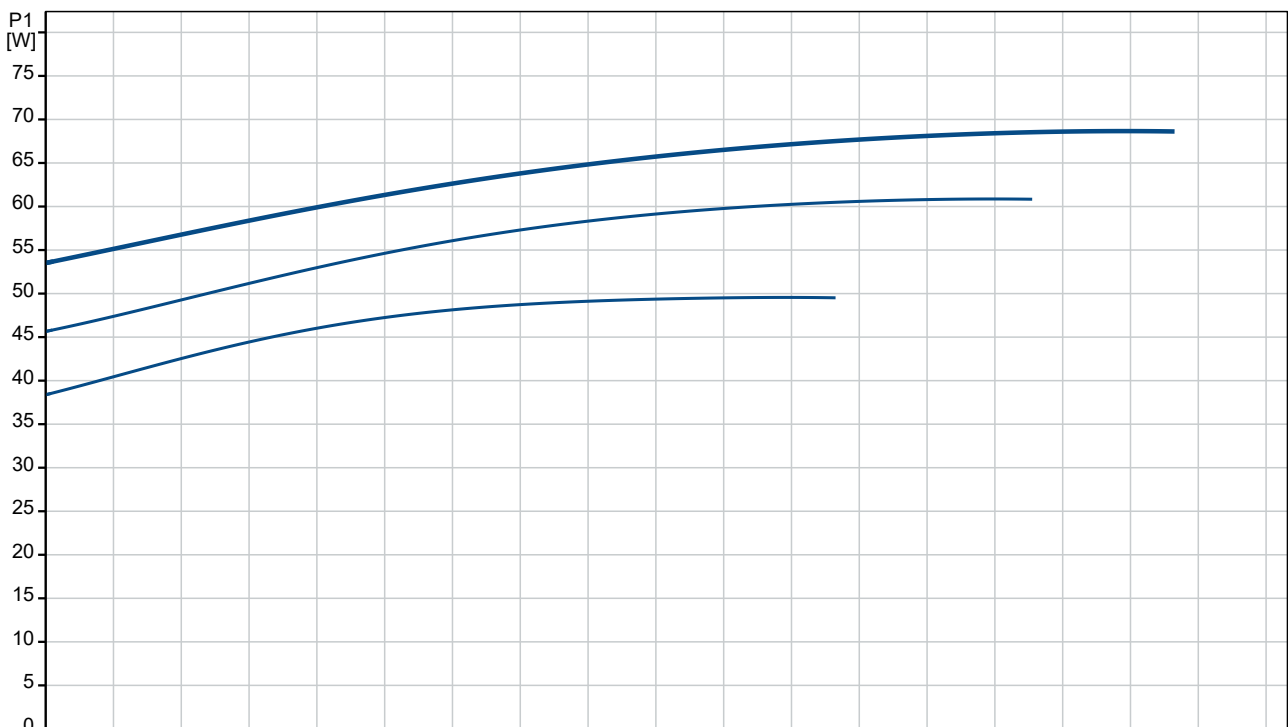

Description	Value
General information:	
Product name:	UPS 25-60 130
Product No:	96281476
EAN number:	5700830383186
Price:	AUD 447
Technical:	
Speed no:	3
Rated flow:	1.9 m ³ /h
Rated head:	3.109 m
Maximum head:	60 dm
TF class:	110
Approvals:	VDE,EAC,RCM
Materials:	
Pump housing:	Cast iron
Pump housing:	EN 1561 EN-GJL-150
Pump housing:	ASTM 30 B
Impeller:	Composite
Impeller:	PES+30% GF
Installation:	
Range of ambient temperature:	0 .. 40 °C
Maximum operating pressure:	10 bar
Type of connection:	G
Size of connection:	1 1/2 inch
Pressure rating for connection:	PN 10
Port-to-port length:	130 mm
Liquid:	
Pumped liquid:	Water
Liquid temperature range:	2 .. 110 °C
Selected liquid temperature:	60 °C
Density:	983.2 kg/m ³
Electrical data:	
Power input in speed 1:	50 W
Power input in speed 2:	60 W
Max. power input:	70 W
Mains frequency:	50 Hz
Rated voltage:	1 x 230 V
Current in speed 1:	0.22 A
Current in speed 2:	0.27 A
Current in speed 3:	0.3 A
Capacitor size - run:	2.5 µF
Enclosure class (IEC 34-5):	IP44
Insulation class (IEC 85):	F
Built-in motor protection:	NONE
Thermal protec:	IMP.
Others:	
Terminal box position:	9H
Net weight:	2.4 kg
Gross weight:	2.54 kg
Shipping volume:	0.004 m ³
Country of origin:	DK
Custom tariff no.:	84137090622081967

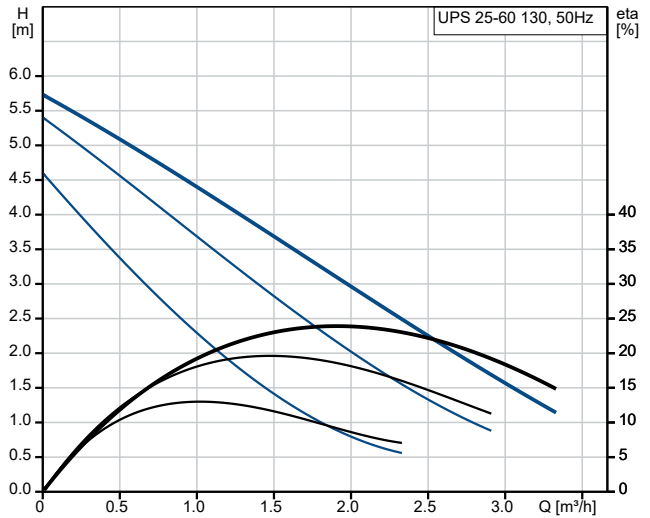

Pumped liquid = Water
 Liquid temperature during operation = 60 °C
 Density = 983.2 kg/m³

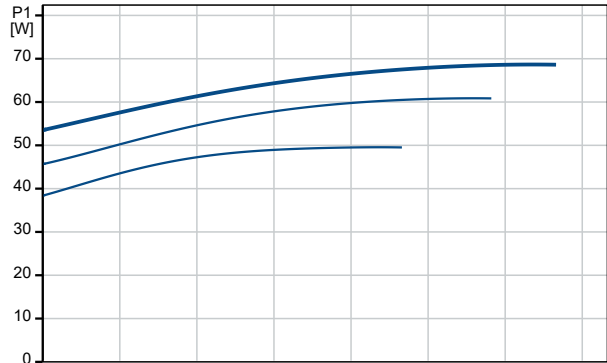

96281476 UPS 25-60 130 50 Hz

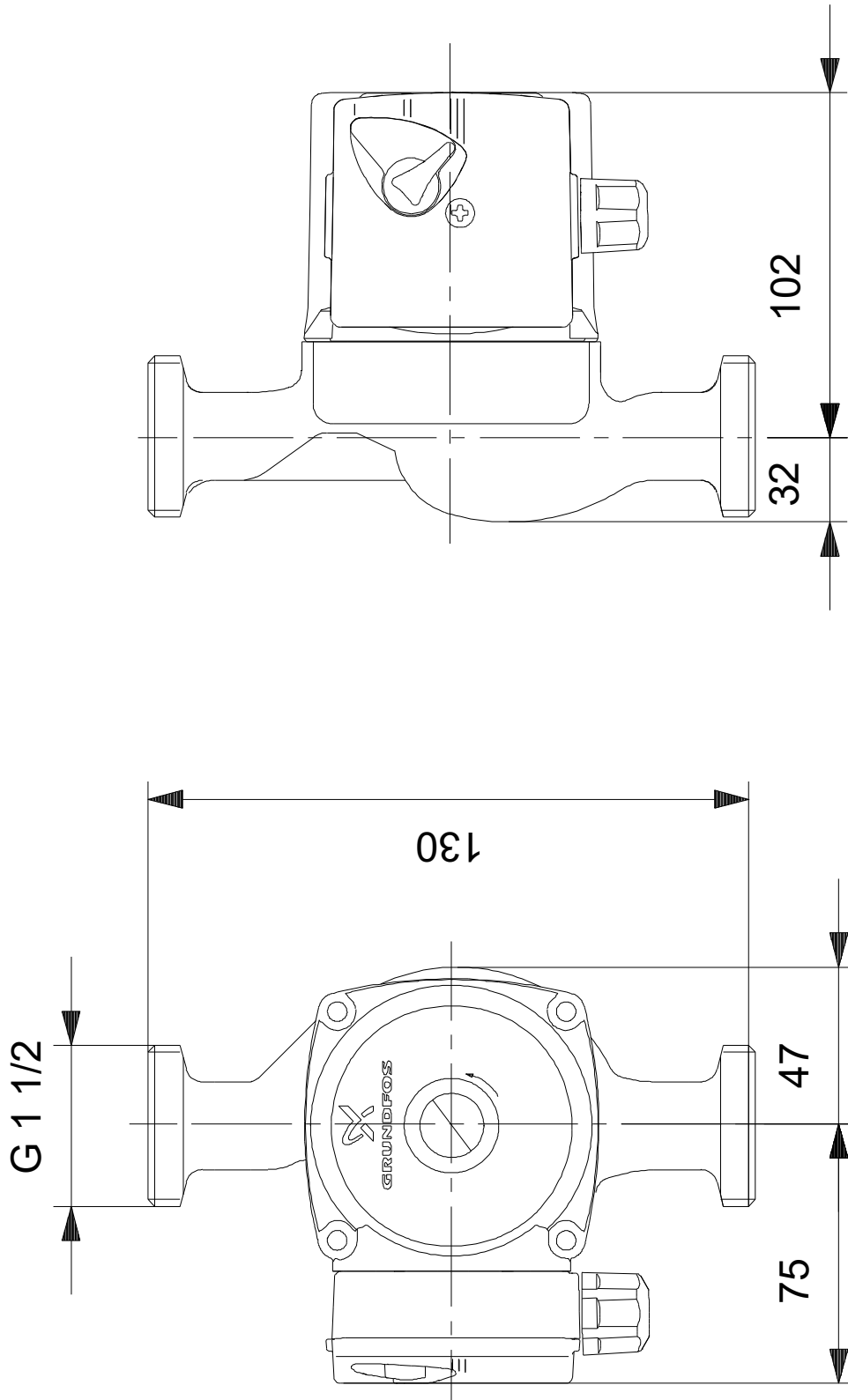

Note! All units are in [mm] unless others are stated.
Disclaimer: This simplified dimensional drawing does not show all details.