

Qty. Description

1 UPS 20-60 N 150



Note! Product picture may differ from actual product

Product No.: [96913096](#)

The pump is of the canned rotor type, i.e. pump and motor form an integral unit without shaft seal and with only two gaskets for sealing.

The bearings are lubricated by the pumped liquid.

The pump has 3-step speed selector.

The pump is characterized by:

- * Ceramic shaft and radial bearings.
- * Carbon axial bearing.
- * Stainless steel rotor can and bearing plate.
- * Corrosion-resistant impeller, Composite.
- * Stainless steel pump housing.

The motor is a 1-phase motor.

No additional motor protection is required.

Liquid:

Pumped liquid: Water
 Liquid temperature range: 2 .. 110 °C
 Selected liquid temperature: 60 °C
 Density: 983.2 kg/m³

Technical:

Rated flow: 2.03 m³/h
 Rated head: 3.473 m
 TF class: 110
 Approvals: CE,EAC,WEEE,RCM

Materials:

Pump housing: Stainless steel
 EN 1.4308
 Impeller: Composite
 PES+30% GF

Installation:

Range of ambient temperature: 0 .. 40 °C
 Amb. max at 80 dgr C liquid: 40 °C
 Maximum operating pressure: 10 bar
 Type of connection: G
 Size of connection: 1 1/4 inch
 Pressure rating for connection: PN 10
 Port-to-port length: 150 mm

Electrical data:

Power input in speed 1: 35 W
 Power input in speed 2: 60 W



Company name: ASC Water Tanks
Created by: Anant Yuvarajah
Phone: 03 8795 7715
Email: sales@asc tanks.com.au
Date: 12/06/2024

Qty. Description

1	Max. power input:	90 W
	Mains frequency:	50 Hz
	Rated voltage:	1 x 240 V
	Current in speed 1:	0.15 A
	Current in speed 2:	0.25 A
	Current in speed 3:	0.37 A
	Capacitor size - run:	2 μ F
	Enclosure class (IEC 34-5):	IP44
	Insulation class (IEC 85):	F
	Built-in motor protection:	NONE
	Others:	
	Terminal box position:	9H
	Net weight:	2.9 kg
	Gross weight:	3.2 kg
	Shipping volume:	0.004 m ³
	Country of origin:	RS

96913096 UPS 20-60 N 150 50 Hz

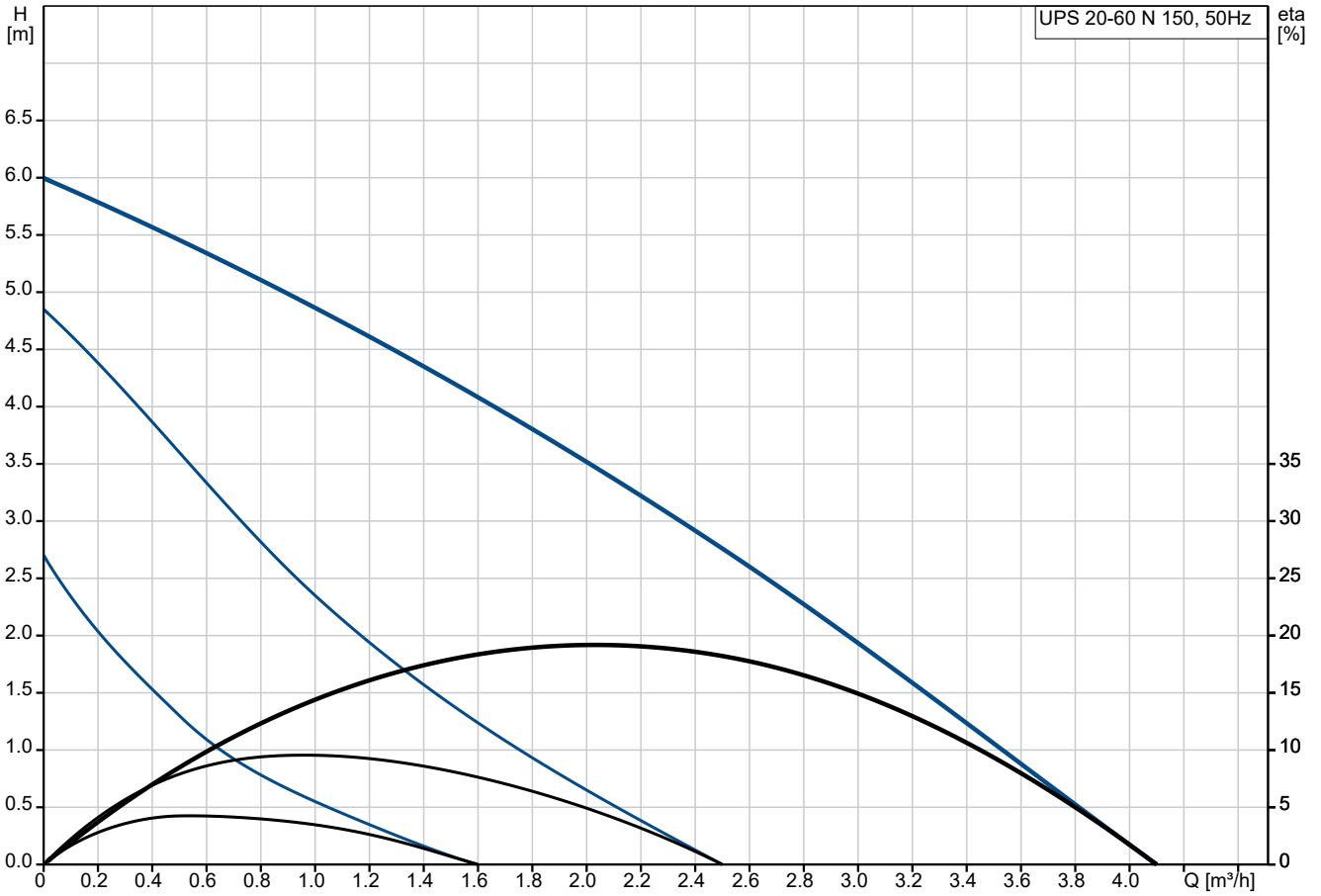

Pumped liquid = Water
 Liquid temperature during operation = 60 °C
 Density = 983.2 kg/m³

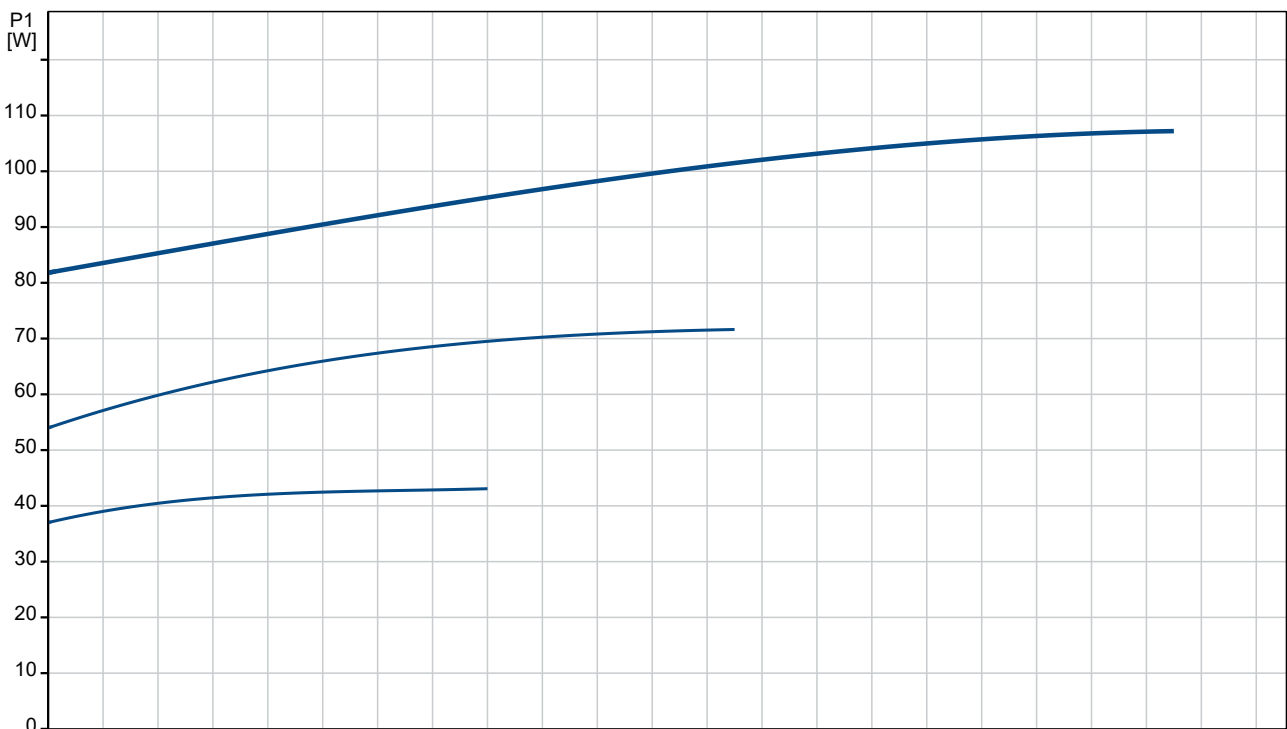

Description	Value
General information:	
Product name:	UPS 20-60 N 150
Product No:	96913096
EAN number:	5700313543779
Price:	AUD 835
Technical:	
Speed no:	3
Rated flow:	2.03 m ³ /h
Rated head:	3.473 m
Maximum head:	60 dm
TF class:	110
Approvals:	CE,EAC,WEEE,RCM
Materials:	
Pump housing:	Stainless steel
Pump housing:	EN 1.4308
Impeller:	Composite
Impeller:	PES+30% GF
Installation:	
Range of ambient temperature:	0 .. 40 °C
Amb. max at 80 dgr C liquid:	40 °C
Maximum operating pressure:	10 bar
Type of connection:	G
Size of connection:	1 1/4 inch
Pressure rating for connection:	PN 10
Port-to-port length:	150 mm
Liquid:	
Pumped liquid:	Water
Liquid temperature range:	2 .. 110 °C
Selected liquid temperature:	60 °C
Density:	983.2 kg/m ³
Electrical data:	
Power input in speed 1:	35 W
Power input in speed 2:	60 W
Max. power input:	90 W
Mains frequency:	50 Hz
Rated voltage:	1 x 240 V
Current in speed 1:	0.15 A
Current in speed 2:	0.25 A
Current in speed 3:	0.37 A
Capacitor size - run:	2 µF
Enclosure class (IEC 34-5):	IP44
Insulation class (IEC 85):	F
Built-in motor protection:	NONE
Thermal protec:	IMP.
Others:	
Terminal box position:	9H
Net weight:	2.9 kg
Gross weight:	3.2 kg
Shipping volume:	0.004 m ³
Country of origin:	RS

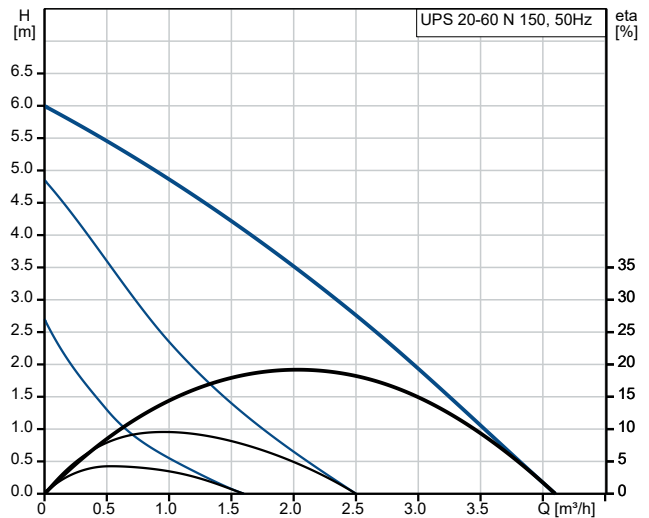

Pumped liquid = Water
 Liquid temperature during operation = 60 °C
 Density = 983.2 kg/m³

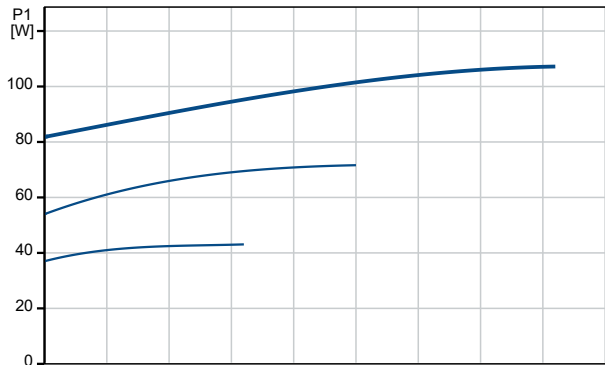

96913096 UPS 20-60 N 150 50 Hz

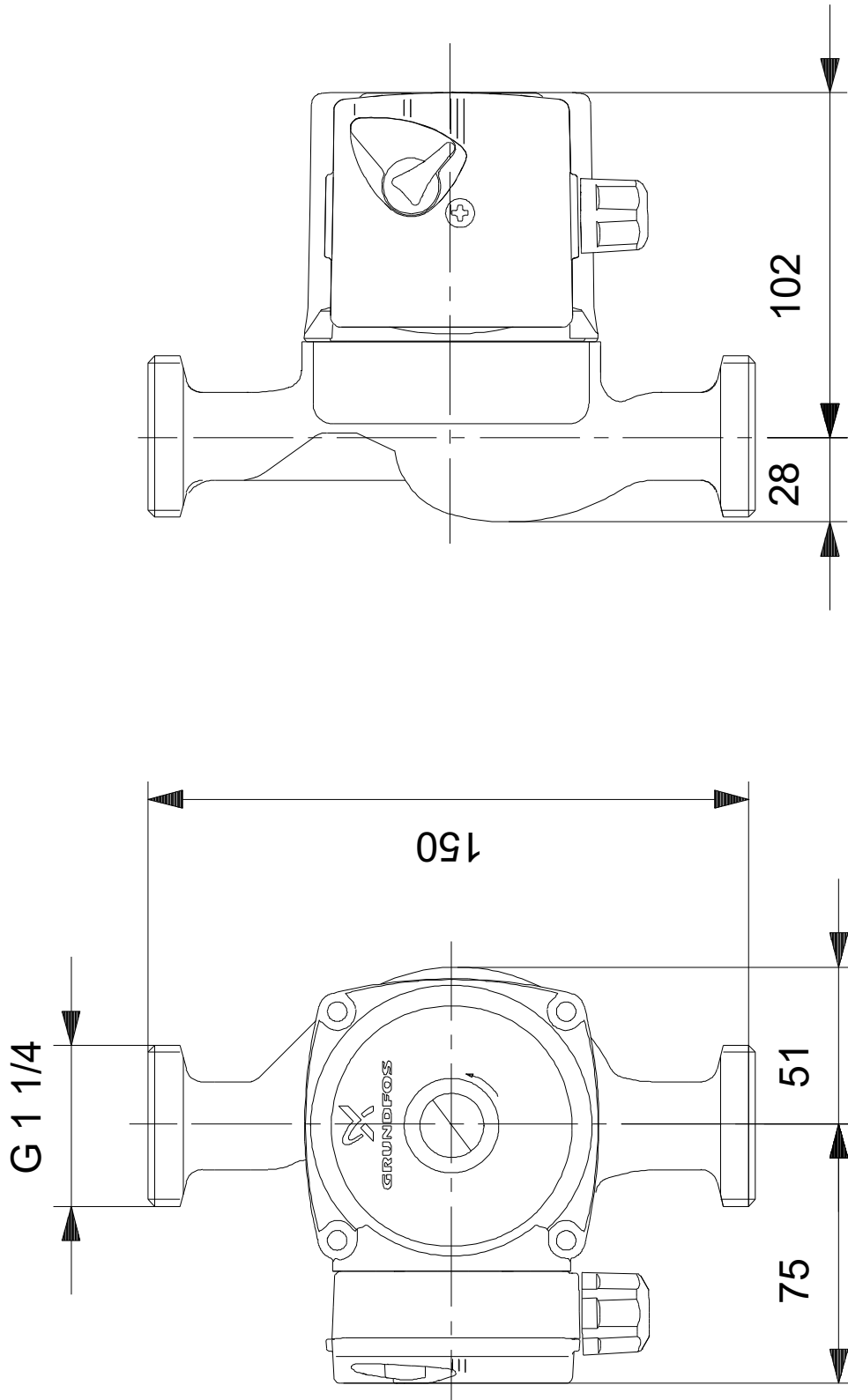

Note! All units are in [mm] unless others are stated.
Disclaimer: This simplified dimensional drawing does not show all details.