



Company name: ASC Water Tanks
Created by: Anant Yuvarajah
Phone: 03 8795 7715
Email: sales@asc tanks.com.au
Date: 26/04/2020

Qty. Description

1 CMB-SP 5-47 I-C-A-A-C-A



Note! Product picture may differ from actual product

Product No.: [98507636](#)

The Grundfos CM Booster self-priming pump with PM2 pressure manager is a compact booster solution for water supply in domestic applications. The pressure booster unit consists of a Grundfos CM self-priming pump and a Grundfos PM2 pressure manager. The pressure manager allows the pump to start and stop automatically according to demand and protects the pump from dry running. The CM Booster self-priming pump can create a suction lift of up to 8 m, and it is very easy to install. When the booster has been connected to the pipework, just plug it into a socket, and the system is operational.

Features

- compact
- easy installation
- self-priming up to 8 m
- automatic resetting of alarms
- dry-running protection
- anti-cycling (leakage detection)
- maximum continuous operating time.

Applications

The Grundfos CM Booster self-priming pump with PM2 pressure manager is mainly used for domestic and light commercial water supply or booster systems.

Liquid:

Pumped liquid: Water
Liquid temperature range: 0 .. 60 °C
Selected liquid temperature: 20 °C
Density: 998.2 kg/m³

Technical:

Pump speed on which pump data are based: 2900 rpm
Rated flow: 78.33 l/min
Rated head: 38 m
Primary shaft seal: AVBE
Approvals and markings: CE,C-TICK
Curve tolerance: ISO9906:2012 3B



Company name: ASC Water Tanks
Created by: Anant Yuvarajah
Phone: 03 8795 7715
Email: sales@asc tanks.com.au
Date: 26/04/2020

Qty.	Description
	Return valve: YES Self-priming: 4 m Start pressure: PM2
	Materials: Pump housing: Stainless steel DIN W.-Nr. 1.4301 AISI 304 Impeller: Stainless steel DIN W.-Nr. 1.4301 AISI 304 Rubber: EPDM
	Installation: Maximum ambient temperature: 55 °C Flange standard: WHITWORTH THREAD RP
	Electrical data: Rated power - P2: 0.9 kW Mains frequency: 50 Hz Rated voltage: 1 x 220-240 V Maximum current consumption: 5.4-5.0 A Rated speed: 2750-2790 rpm Enclosure class (IEC 34-5): IP55 Insulation class (IEC 85): F Type of cable plug: AU Mains cable: 1.5 m
	Others: Net weight: 18 kg Gross weight: 23.3 kg



Company name: ASC Water Tanks
Created by: Anant Yuvarajah
Phone: 03 8795 7715
Email: sales@asc tanks.com.au
Date: 26/04/2020

98507636 CMB-SP 5-47 I-C-A-A-C-A 50 Hz

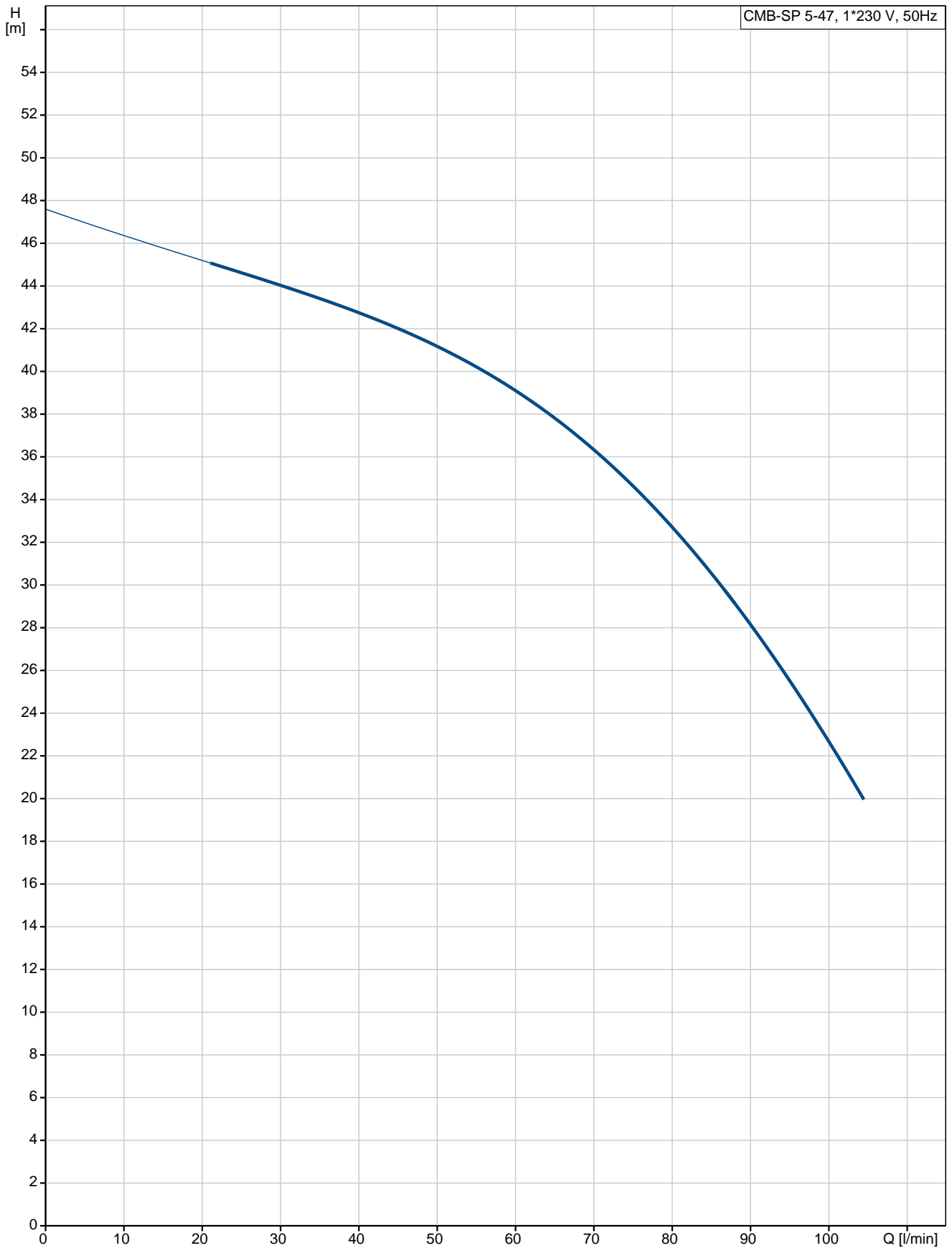



Company name: ASC Water Tanks
Created by: Anant Yuvarajah
Phone: 03 8795 7715
Email: sales@asc tanks.com.au
Date: 26/04/2020

Description	Value
General information:	
Product name:	CMB-SP 5-47 I-C-A-A-C-A
Product No:	98507636
EAN number:	5711496304699 5711496304699
Technical:	
Pump speed on which pump data are based:	2900 rpm
Rated flow:	78.33 l/min
Rated head:	38 m
Impellers:	5
Primary shaft seal:	AVBE
Approvals and markings:	CE,C-TICK
Curve tolerance:	ISO9906:2012 3B
Model:	A
Return valve:	YES
Self-priming:	4 m
Start pressure:	PM2
Materials:	
Pump housing:	Stainless steel DIN W.-Nr. 1.4301 AISI 304
Impeller:	Stainless steel DIN W.-Nr. 1.4301 AISI 304
Rubber:	EPDM
Installation:	
Maximum ambient temperature:	55 °C
Flange standard:	WHITWORTH THREAD RP
Liquid:	
Pumped liquid:	Water
Liquid temperature range:	0 .. 60 °C
Selected liquid temperature:	20 °C
Density:	998.2 kg/m ³
Electrical data:	
Rated power - P2:	0.9 kW
Mains frequency:	50 Hz
Rated voltage:	1 x 220-240 V
Maximum current consumption:	5.4-5.0 A
p max system:	10 bar
Rated speed:	2750-2790 rpm
Enclosure class (IEC 34-5):	IP55
Insulation class (IEC 85):	F
Motor protec:	TP 211
Type of cable plug:	AU
Mains cable:	1.5 m
Others:	
Net weight:	18 kg
Gross weight:	23.3 kg

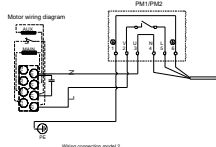
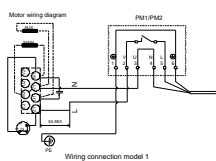
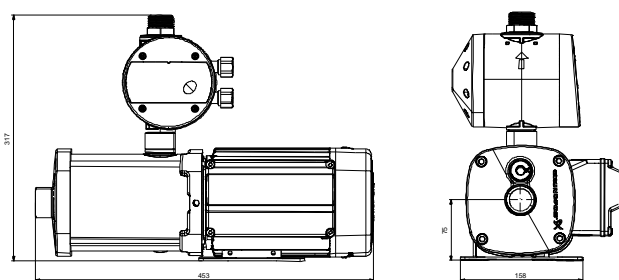
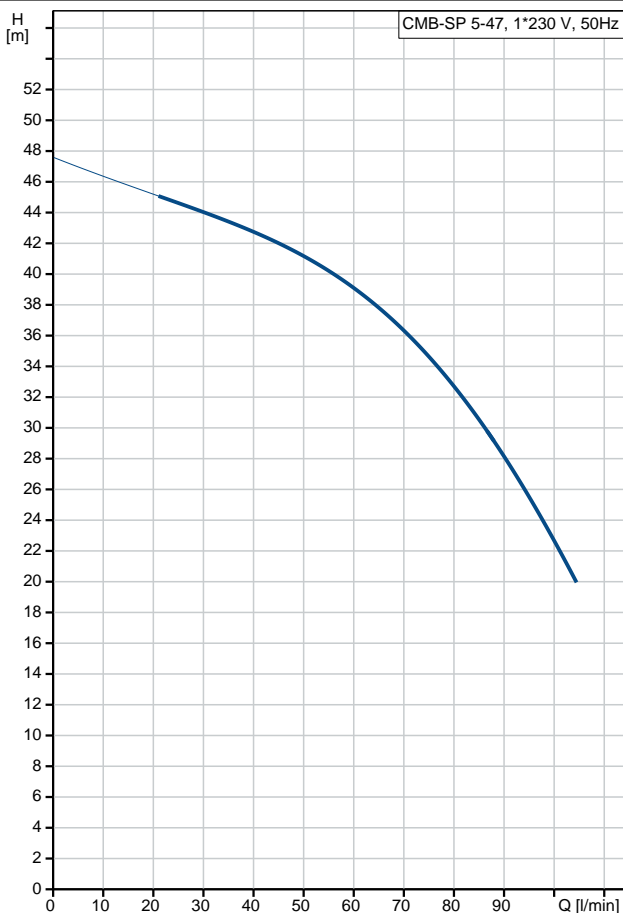

- Australian plug: IEC type I, AS/NZS3112, 1.5 m
- Schuko plug: IEC Type E/F, CEE7/7, 1.5 m
- US plug: IEC type B, NEMA 0-15P, 1.5 m
- NO PLUG, 1.5 m



Company name: ASC Water Tanks
Created by: Anant Yuvarajah
Phone: 03 8795 7715
Email: sales@asc tanks.com.au
Date: 26/04/2020

98507636 CMB-SP 5-47 I-C-A-A-C-A 50 Hz

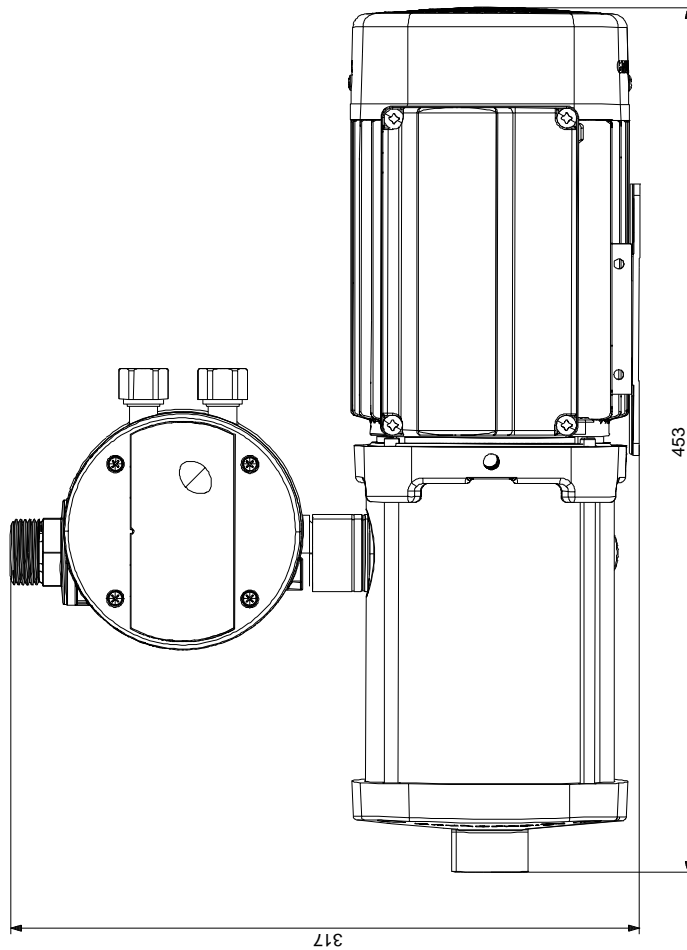
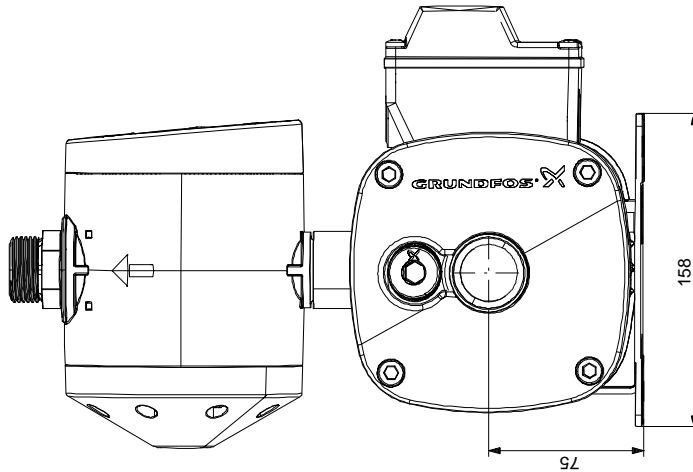

Note! All units are in [mm] unless others are stated.
Disclaimer: This simplified dimensional drawing does not show all details.



Company name: ASC Water Tanks
Created by: Anant Yuvarajah
Phone: 03 8795 7715
Email: sales@asc tanks.com.au
Date: 26/04/2020

98507636 CMB-SP 5-47 I-C-A-A-C-A 50 Hz

Australian plug: IEC type I,
 AS/NZS3112, 1,5 m
 Schuko plug: IEC Type E&F,
 CEE7/7, 1,5 m
 US plug: IEC type B, NEMA
 5-15P, 1,5 m
 NO PLUG, 1,5 m

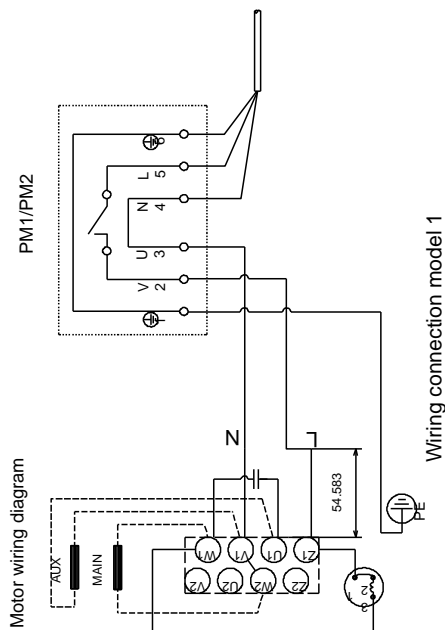
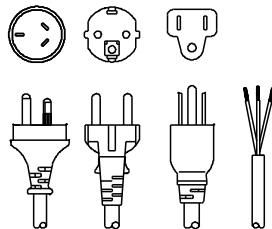

Wiring connection model 1

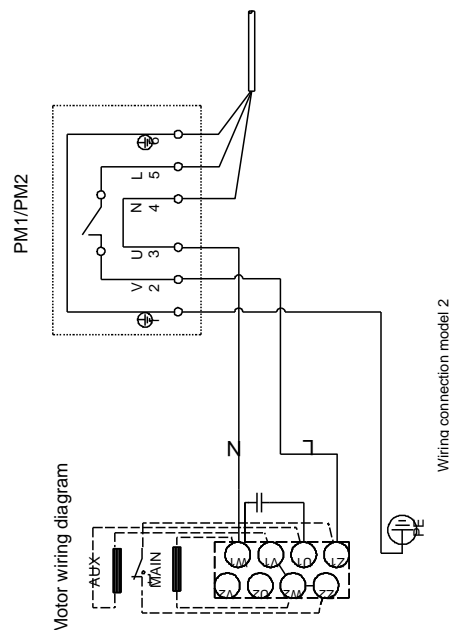

Wiring connection model 2

Note! All units are in [mm] unless others are stated.