

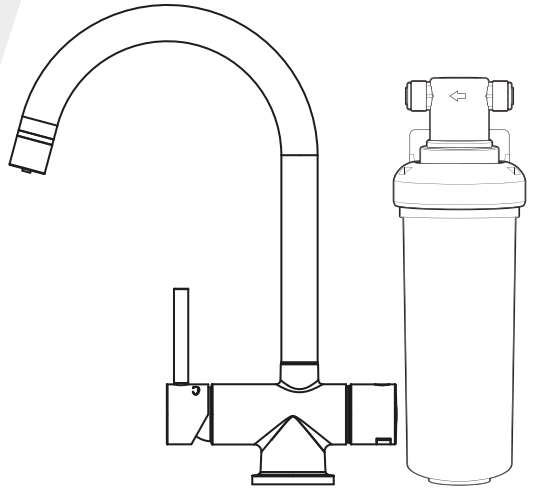

Puretec[®]
PERFECTING WATER



ATTENTION: For Australasian Consumers the LED filter change reminder light on this tap has been disabled/ removed in order to comply with new Legislation "Consumer Goods (Products Containing Button/Coin Batteries) Safety Standard 2020 - F2020L01658" This does not affect the performance of the filter system in any way and you are eligible for Puretec's free email cartridge reminder service.



User Guide

Z1 Tripla Series

Quick Twist Filter System with Tripla LED Mixer Tap



WaterMark

AS/NZS 3497
Licence No. WM 74617
Pro-Switch

What's Inside

| | |
|-------------------------------------|---|
| Operation | 3 |
| Cartridge Replacement..... | 3 |
| Servicing..... | 4 |
| Technical Information | 4 |
| Recommended Working Pressures | 4 |

PART 1 Mixer Tap Assembly

| | |
|---|----|
| Mixer Tap Installation Guide..... | 5 |
| Assembly..... | 6 |
| Mixer Tap Connections | 7 |
| Battery Installation | 9 |
| Replacement of Ceramic Disc Cartridge(s)..... | 10 |

PART 2 Filter Cartridge Installation

| | |
|--|----|
| Installation Requirements | 10 |
| Installation Procedure..... | 11 |
| Cartridge Installation/Changeout | 12 |
| Use Guidelines | 14 |

| | |
|----------------------------------|----|
| WELS Ratings..... | 15 |
| Tripla T1 Parts Description..... | 16 |
| Tripla T2 Parts Description..... | 17 |
| Tripla T3 Parts Description..... | 18 |
| Tripla T4 Parts Description..... | 19 |
| Tripla T5 Parts Description..... | 20 |
| Tripla T6 Parts Description..... | 21 |
| Performance Data..... | 22 |
| Warranty..... | 23 |

Puretec Customer Service

Thank you for purchasing Puretec Z1 Tripla water filter system. Your system is a proven performer manufactured from only quality materials and components and will give years of 'spring fresh' water free of impurities if maintained properly.

The Puretec Z1 system cartridges need replacing regularly to maintain optimum performance. This is a simple procedure when following instructions. For cartridge replacements contact your nearest Puretec stockist.

The system is designed for metropolitan supply water but can be used in other situations. For other types of water supply please contact your local Puretec stockist or call our Puretec Customer Service Helpline prior to installing the tap.

Customer Service Helpline **1300 140 140** (Australia) **0800 130 140** (New Zealand).

Caution: Do not use with water that is microbiologically unsafe or with water of unknown quality without adequate disinfection before or after the system. This product must be installed in accordance with local plumbing regulations by a licensed plumber.

Operation

The Puretec Z1 Tripla system is designed to run economically for many years, dependent on the initial installation and periodical maintenance.

Flush systems for 10 minutes after any period of non-use more than 2 days. For a period of non-use of 2 weeks or more, it may be necessary to replace cartridge.

Tap Surface - should only be cleaned with liquid detergent or soap and water. Under no circumstance should any abrasive or acid base cleaning agents be used.

Installation Note: A water filter system/tap, like any product, has a limited life and may eventually fail. Also sometimes failure happens early due to unforeseen circumstances. To avoid possible property damage, this product should be regularly examined for leakage and/or deterioration and replaced when necessary. A drain pan, plumbed to an appropriate drain or outfitted with a leak detector, should be used in those applications where any leakage could cause property damage, and/or the water supply should be turned off if no one is home/present.

Cartridge Replacement

To maintain the high quality of the purified water the cartridges need changing every 6-12 months (dependent on water quality and usage).

When replacing cartridge, ensure you reset the LED reminder light by removing/replacing the battery from the rubber seat. Please refer to page 8 for a detailed diagram.

Order **Z1-R** for a replacement cartridge to suit your Z1 Tripla system.

Servicing

Periodically clean the aerator for any lodged sediment that may restrict flow. A Puretec water filter is highly recommended on all incoming lines for product longevity.

Should it be necessary to have your mixer serviced while under warranty, please carry out the following procedure:

1. Firstly call the plumber, preferably the one that has installed it, (most problems are caused by the supply lines not being cleaned out properly, prior to connecting the mixers).
2. Make sure that the plumber has installed your mixer according to the Instruction Guide.
3. If the plumber is satisfied that he cannot rectify the problem then contact your plumbing supply store or your local Puretec stockist.

Important: We do not recommend the dismantling of any internal part of the mixer as this will breach your warranty.

Technical Information

Puretec mixers can be used in conjunction with:

- Pressure storage hot water system
- Any mains water pressure not exceeding 520 kPa
- Maximum hot water temperature of 60°C
- Instantaneous hot water system
- Any filtered water supply

Recommended Working Pressures

- Minimum working pressure 200 kPa (7.5 psi)
- Maximum working pressure 520 kPa (72.5 psi)

It should be noted that water mains pressure builds up during off peak periods, mainly at night, sometimes doubling or trebling normal daytime pressures.

Note: Not suitable for unequal pressure. On high pressure areas where the pressure exceeds the recommended working pressure as indicated above, an approved pressure limiting valves must be installed or warranty is voided.

PART 1

Fig. 1 - Mixer Tap Installation Guide

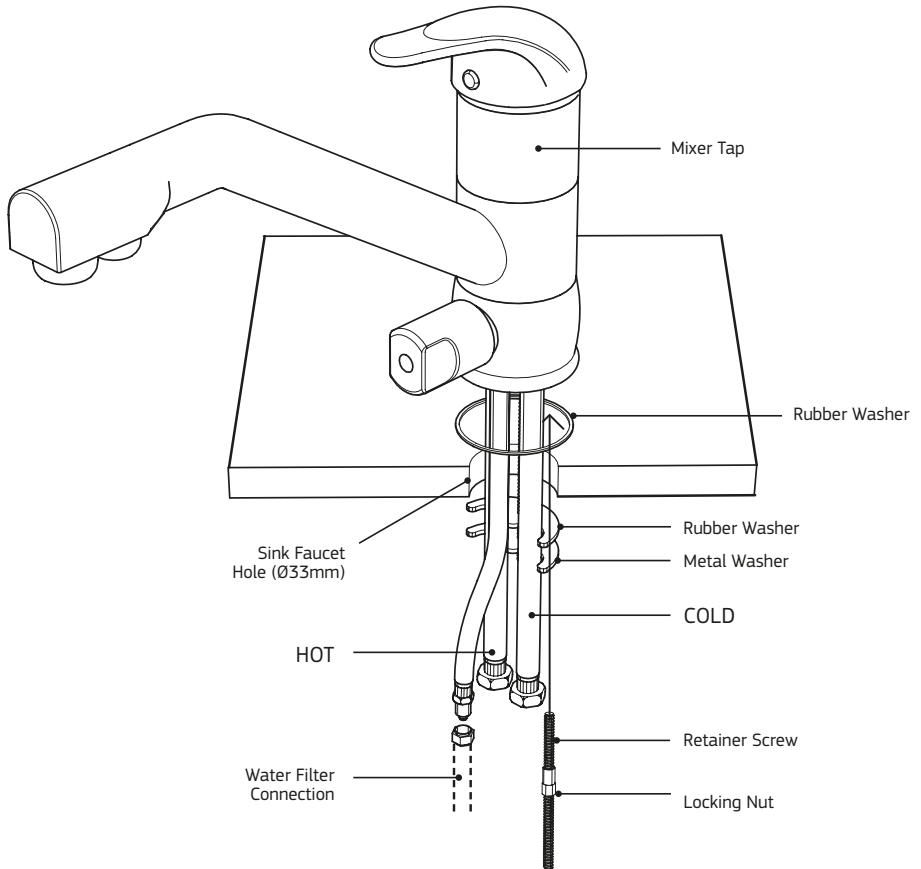

Note: It is important to flush out the supply pipes to the mixer before connecting the flexible hoses, with the initial installation, so no foreign matter can enter into the cartridges.

A Puretec Water Filter is highly recommended for product longevity.

Fig. 2 - Tap Assembly

Step 1. Connect the hoses to the faucet and tighten them. Refer to page 7 for connection patterns.

Only use hand to screw the flexible hose. Do not over tighten. Don't use any tools.

Step 2. Put brass base with o-ring to the bottom of the faucet.

Step 3. Put the hoses through the basin or sink. Required through hole size is $\varnothing 33\text{mm}$.

Step 4. Place the retainer screw through the hole in each spacer and screw to the hole on the bottom of the faucet.

Then, use a wrench to lock the locking nut.

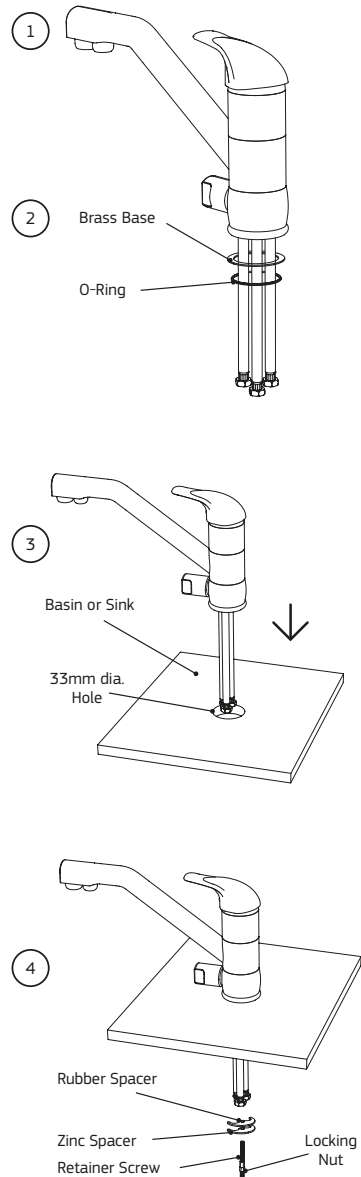

Fig. 3 - Water Connection Patterns

For Z1-T1 & Z1-T2

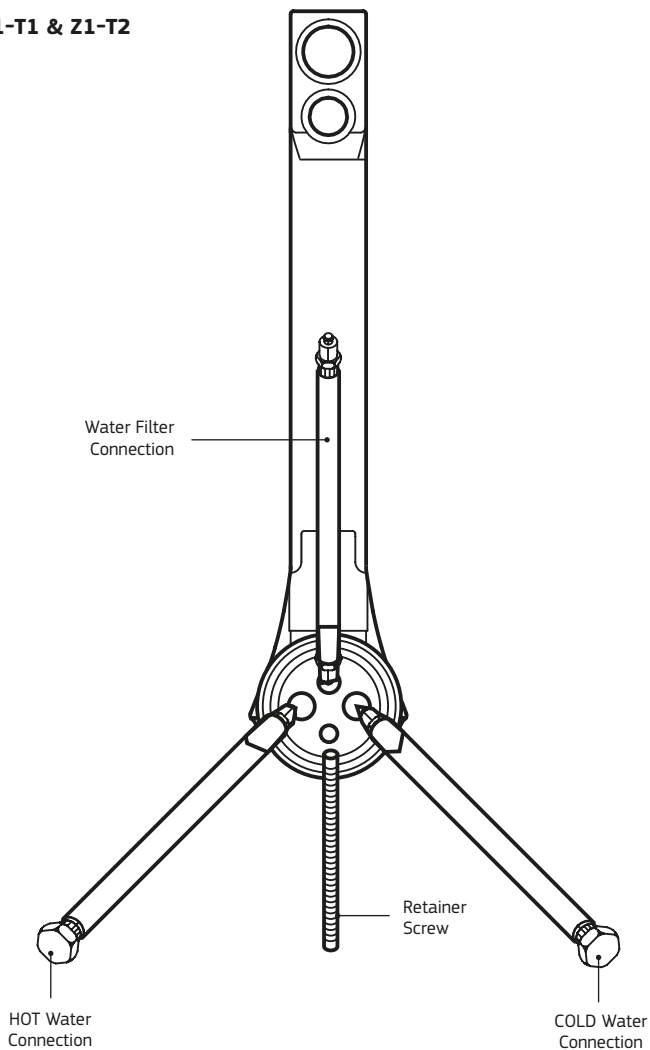
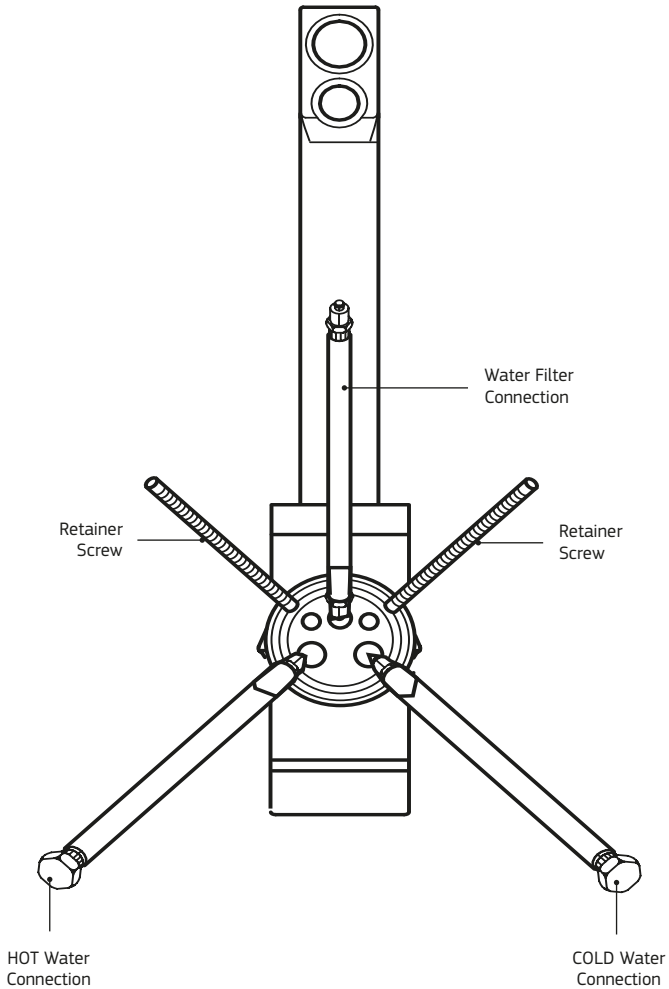

Fig. 4 - Water Connection Patterns

For Z1-T3 to Z1-T6



Battery Installation - LED reminder light

Important note: Battery must be replaced when changing cartridges.

1. Remove the black battery seat from the faucet canopy.



Note: Red light flashes twice and then followed by the blue light.



2. Install battery into the battery seat, positive side up.



Positive
side up



Negative on
the PCB

3. Reinstall battery seat assembly into the faucet canopy.

4. Blue light flashes during normal operation.

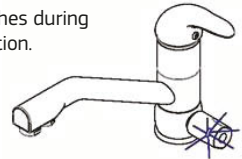

5. Red light flashes indicates your cartridges are due to be changed (usage has exceeded 3,000 minutes or 12 months). **Please change the battery when changing the filter cartridge(s).**



WARNING!

This product contains a button battery. Accidental ingestion may occur and can be fatal. Please keep out of reach from infants. If you suspect an accidental ingestion please contact emergency services.

Replacement of Ceramic Disc Cartridge(s)

1. Hot/Cold Outlet
 - Remove hot and cold water indicator then release screw in lever and lift lever off, now you can unscrew dome cap and loosen the cartridge lock nut.
 - Lift out old cartridge and clean inside making sure no old O-rings are still stuck inside cartridge housing.
 - Insert new cartridge making sure O-rings on bottom of new cartridge have not fallen off and lugs in bottom of cartridge line up with holes in cartridge housing.
 - Now you can tighten lock nut with a torque wrench to 14 newton meters, then reinstall dome cap, lever screw and hot and cold water indicator.

2. Filtered/Rain Ancillary Outlet
 - Remove front button cover using fine-edged 1.2mm screwdriver.
 - Unscrew handle then remove cartridge by unscrewing it anti-clockwise, using 5/8" socket. Install cartridge by completing removal instructions as above, in reverse order.
 - Ensure cartridge is firmly tightened not over tightened.

PART 2

Filter Installation

This system comes complete with an installation kit enabling it to be connected to 15mm (½") male thread.

Installation requirements

1. 15mm (½") Cold water line - mains only
2. Min/Max pressure: 200 - 520 kPa. Pressure over 500 kPa requires a pressure limiting valve to be installed.

3. Supply temperature 0° - 38°C (protect from freezing).
4. Suitable location for faucet.

Alternative fittings may be required if being connected to anything other than existing 15mm (½") copper pipe (copper piper NOT included). No electrical or drainage requirements needed.

Installation Procedure

Installation Note: A water filter system/tap, like any product, has a limited life and may eventually fail. Also sometimes failure happens early due to unforeseen circumstances. To avoid possible property damage, this product should be regularly examined for leakage and/or deterioration and replaced when necessary. A drain pan, plumbed to an appropriate drain or outfitted with a leak detector, should be used in those applications where any leakage could cause property damage, and/or the water supply should be turned off if no one is home/present.

INSTALLATION MUST BE COMPLETED BY A LICENCED PLUMBER. FAULTY OPERATION DUE TO UNQUALIFIED PERSONS WILL RESULT IN VOIDED WARRANTY COVERAGE.

1. Select suitable location that is close to the point of filtered water delivery (eg. sink). Remember to allow access room for changing filters and a suitable place where water spillage will not cause damage. Location should not be in direct sunlight.
2. Isolate water supply and cut copper pipe ready to install the tee adaptor and ballvalve.
3. Connect the SmartTee™ to the multivalve with a piece of white tubing (see Fig. 7).
4. Install filter cartridge by positioning it in the desired location, marking the position of fixing hole and fixing with bracket screw. Z1 Tripla Series can be mounted horizontally or vertically. Allow room for the connecting tubes. Ensure flow arrow on cartridge is in direction of water flow.
6. Fit the stem to tube reducers into either side of the filter by pushing the fittings into the 3/8" quick-connect fittings already installed on the filter head (for quick-connect fittings see Fig. 6).
5. Fit tubing into 1/4" connectors (stem to tube reducers). Allow slack in the tubing. Connect the tubing into the filtered water flexible hose securing with the nut found on the flexible hose (plain). An alternative plain hose with a larger fitting connection is supplied but required with the Z1 installation.

6. Connect cold water flexible hose (blue streak) to cold mains water supply and the hot water flexible hose (red streak) to the hot water supply.
7. Restore water supply & check for leaks, rectifying them, if any, before leaving the unit.
8. Run the system for at least 5 minutes to remove carbon fines. Water may appear milky, but this is normal and is only tiny air bubbles that will clear after a short period.

Cartridge Installation/Changeout

1. Rotate the old cartridge counterclockwise 1/4 turn, pull it out and dispose of it.
2. Remove all packaging from the new cartridge, including any wraps or caps (if applicable).
Replacement cartridge: **Z1-R**
3. Insert the new cartridge into the filter head and rotate clockwise 1/4 turn.
4. Reset LED indicator by following instructions on page 6.
5. Turn on the water and check for leaks. If leaks occur, repeat step 3. If leaks persist, isolate the water supply to the system, discontinue use and call your supporting dealer.
6. Flush filter for 5 minutes before use or until water runs clear.

Use Guidelines

- Minimum operating pressure 200 kPa.
- Maximum operating pressure 520 kPa.
- Do not allow exposure to temperatures below 0°C, protect from freezing.
- Maximum operating temperature 38°C.
- Nominal flow rate 5.5 Lpm.
- This system must be installed according to local plumbing codes on the cold water line - mains only.
- Replacement Cartridge: **Z1-R**
- This system requires regular replacement of the filter cartridge to maintain proper operation. Varying chlorine, sediment, or organic substance levels may affect replacement frequency.
- Be sure to change the filter cartridge at least every 30,000 litres or 6 - 12 months whichever ever occurs first; or whenever you detect a change in taste, odour, or decrease in flow.

Caution: Do not use with water that is microbiologically unsafe or of unknown quality without adequate disinfection before or after the system.

Fig. 5 - Installation Diagram

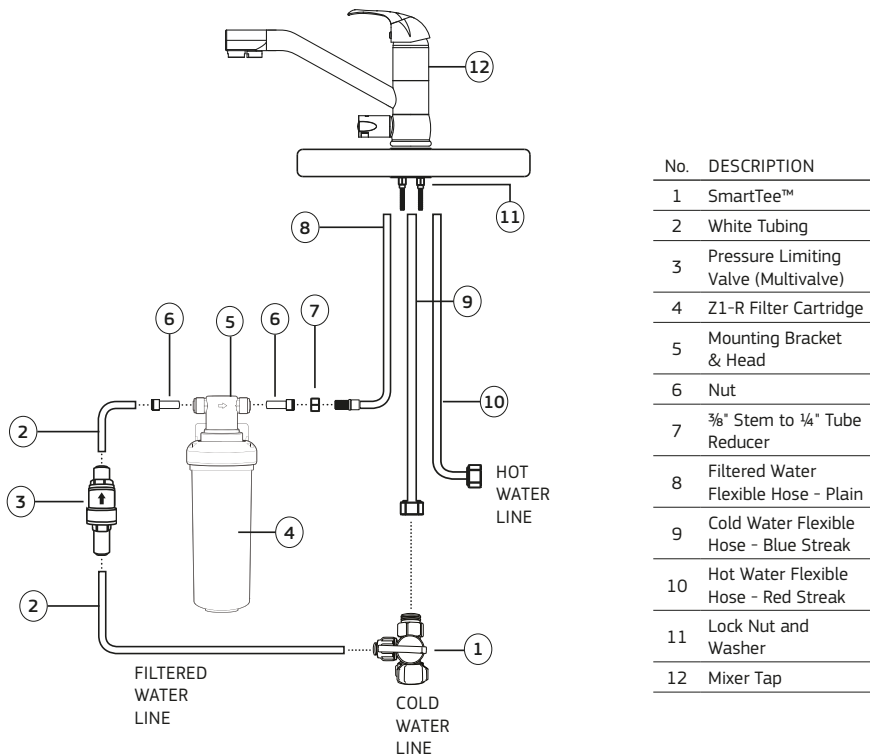
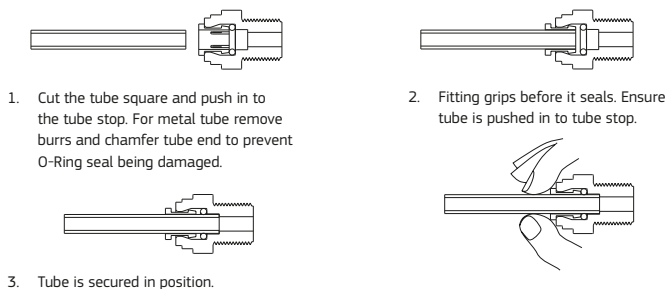

Fig. 6 - How To Use Quick Connect Fittings



DISCONNECTION PROCEDURE

4. Push collet against body and slide tube out of fitting.

Figure 7 - SmartTee™ Quick Connect Fitting

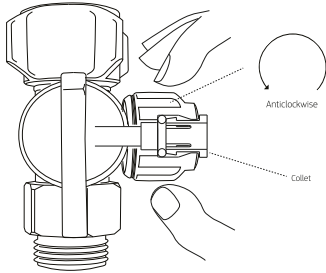

1. Turn the quick connect nut on the SmartTee™ anticlockwise to release the collet.

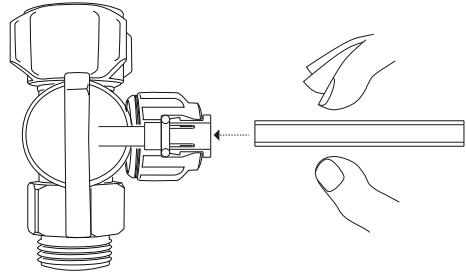

2. Cut the tube square and push into into the tube stop (inside the collet). For metal tube; remove burrs and chamfer tube end to prevent O-ring seal being damaged.

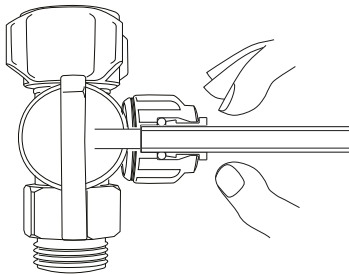

3. The fitting grips before it seals. Ensure the tube is pushed all the way into the tube stop.

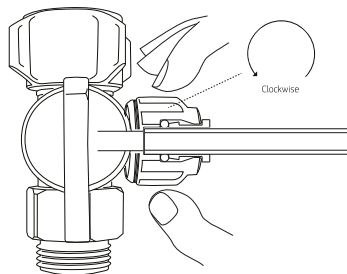

4. Once the tube is secured in position, turn the quick connect nut clockwise to secure.

Note: Hand tighten only. Do not overtighten.

DISCONNECTION PROCEDURE

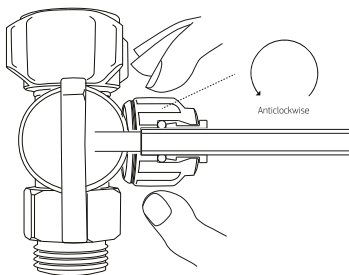

5. Turn the quick connect nut on the SmartTee™ anticlockwise to release the collet.

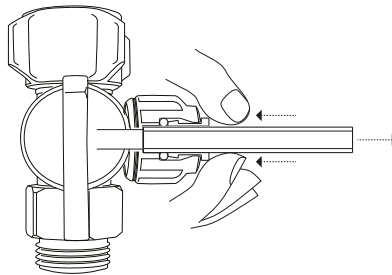

6. Push the collet against the quick connect nut and slide tube out of fitting.

WELS Rating for Tripla Taps

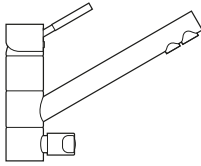

TRIPLA-T1

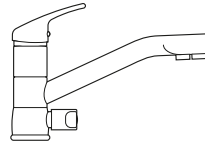

TRIPLA-T2

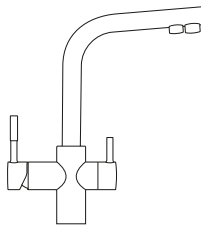

TRIPLA-T3

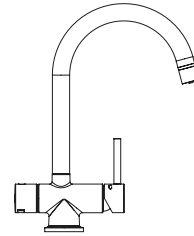

TRIPLA-T4

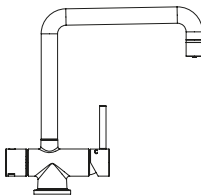

TRIPLA-T5

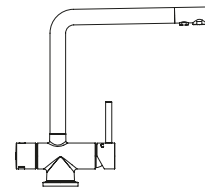

TRIPLA-T6



Fig 8. - Tripla T1 Parts Discription

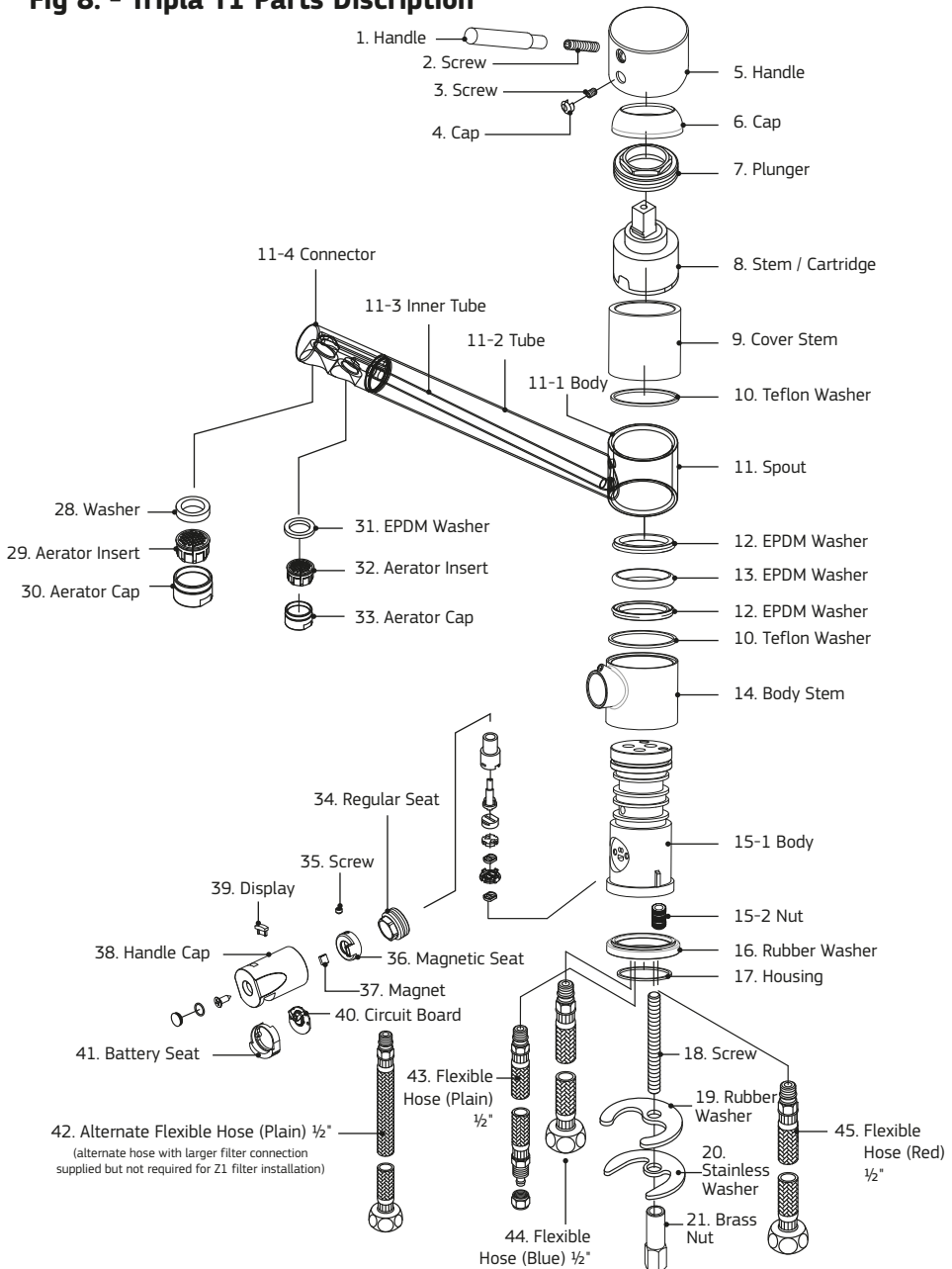

Fig. 9 - Tripla T2 Parts Description

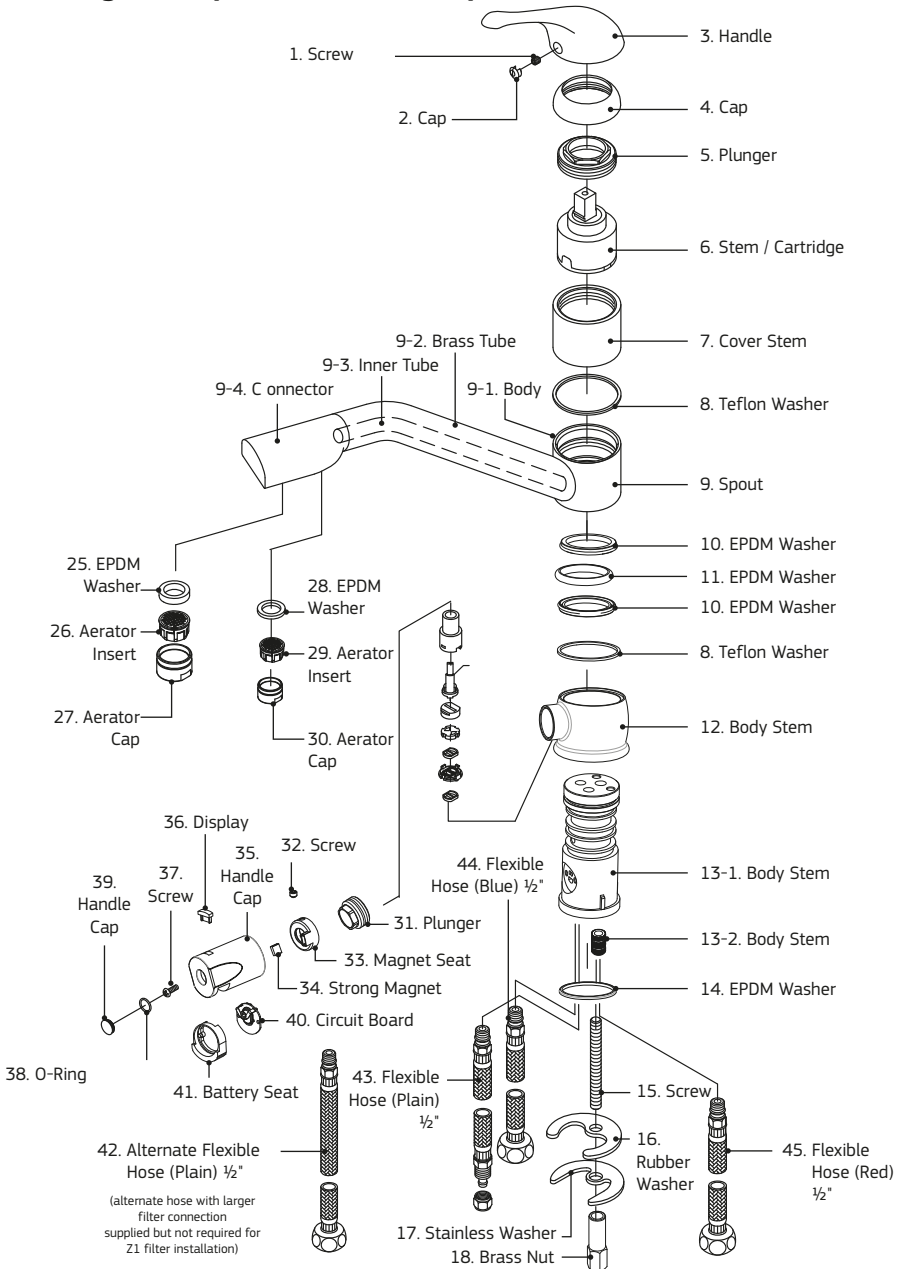

Fig. 10 - Tripla T3 Parts Description

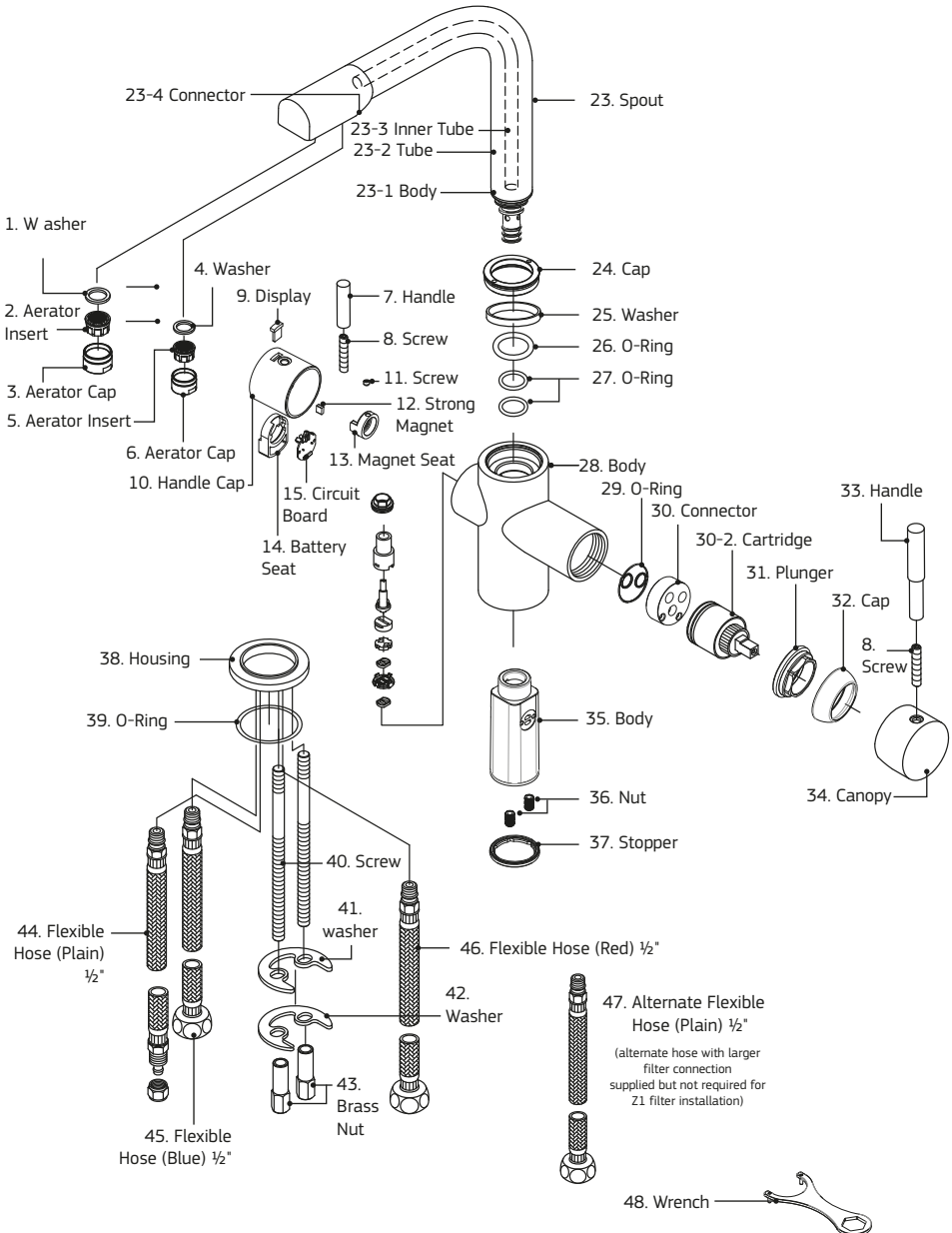

Fig. 11 - Tripla T4 Parts Description

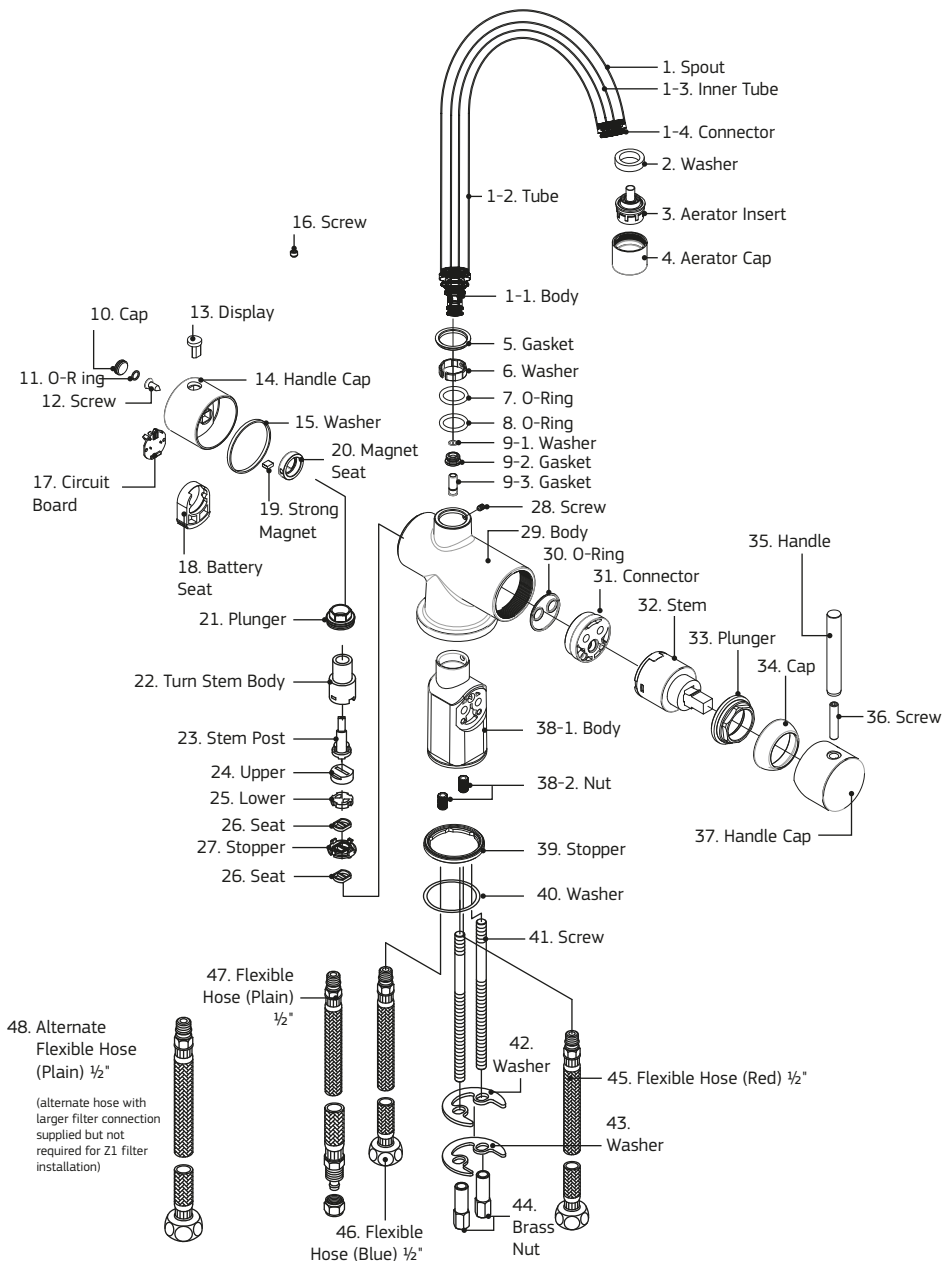

Fig. 12 - Tripla T5 Parts Description

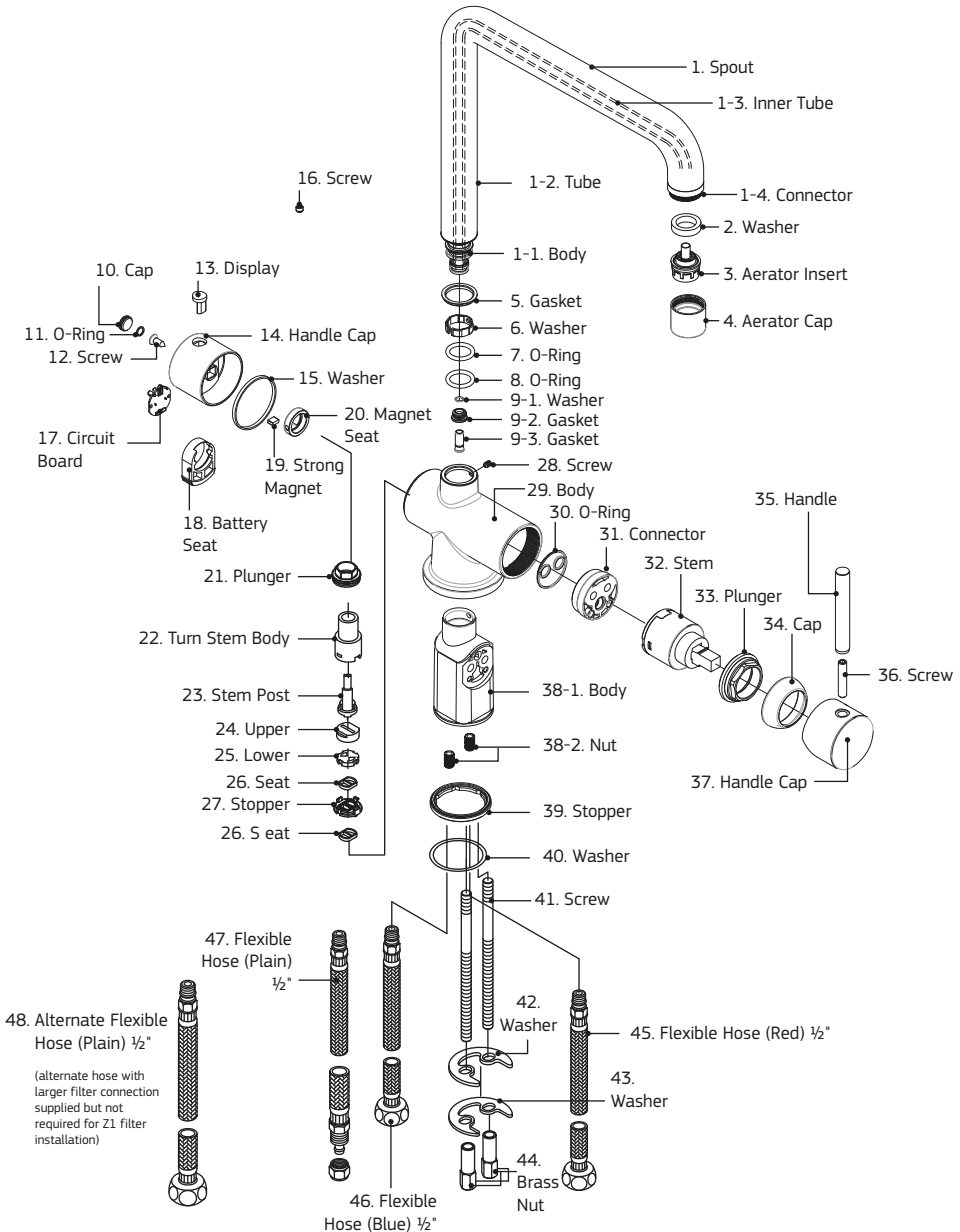
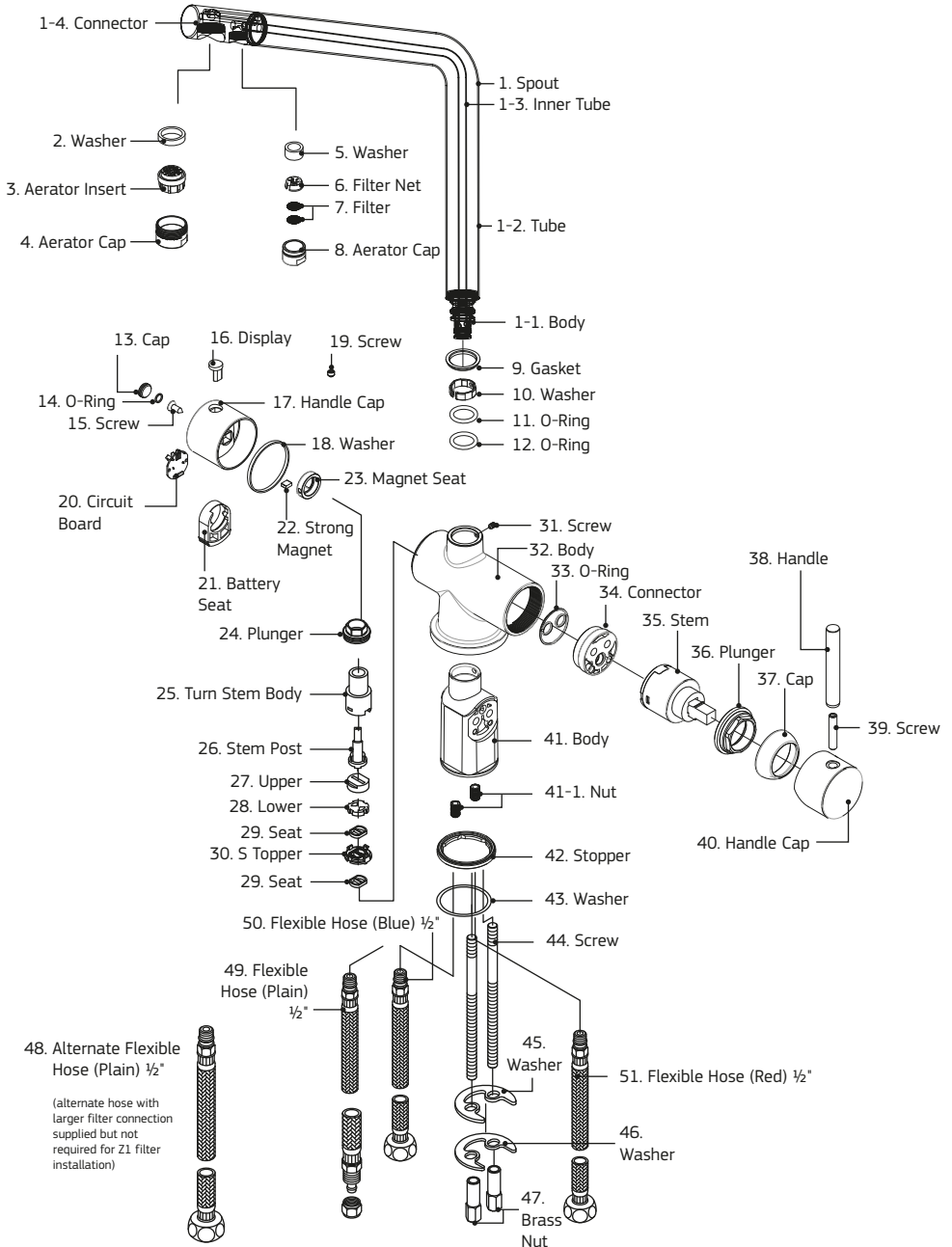

Fig. 13 - Tripla T6 Parts Description



Performance Data

| Substance | Guidelines* | Average Influent Concentration | Max Effluent Concentration | Min Percent Removal | Average Effluent Concentration | Average Percent Removal |
|---|-------------------------------|--------------------------------|----------------------------|---------------------|--------------------------------|-------------------------|
| NSF Standard 42 Drinking Water Treatment Units | | | | | | |
| Chlorine (23,000 L) | 5 - Health 0.6 - Aesthetic | 2.1 | 0.3 | 50% | 0.25 | >94% |
| Standard 53 Cyst Live Cryptosporidium POU/POE | | | | | | |
| Cyst | <1 | 100,000 | ND (1) | 99.98% + | ND (1) | 99.99% |

| Test Parameters | |
|----------------------|------|
| Hardness, Total mg/L | 120 |
| TDS mg/L | 290 |
| Temp deg C | 21°C |
| Turbidity NTU | 0.1 |
| pH | 7.57 |

*Australian Drinking Water Guidelines - 1996
ND = Not Detected

This appliance meets the domestic water treatment appliance Standards AS/NZS3497 for the following water treatment processes:

| Class | Treatment type | Function | Pass |
|------------|--|--|------|
| I | Microbiological Status | | |
| | Bacteriostatic | Will stop bacteria increasing, but will not remove them unless II(a) is passed | N/A |
| II | Microbiological Treatment | | |
| II (a) | Bacteria Removal | Will remove or inactivate bacteria | YES |
| II (b) | Virus Removal | Will remove or inactivate virus | YES |
| II (c) | Protozoa Removal | Will remove or inactivate Cryptosporidium and Giardia, but will not remove or inactivate bacteria and viruses unless II(a) and II(b) is passed | YES |
| III | Turbidity & Particulate Reduction | Reduces cloudiness | YES |
| IV | Taste & Odour Reduction | Reduces taste & odours | YES |
| V | Chemical Treatment | Decreases chlorine | YES |

Notes

Puretec water care products are designed, manufactured and supported by Puretec Pty Ltd the name you can trust for viable and proven water solutions. The complete range of Puretec products are developed, refined, made to meet and exceed stringent specifications for the worldwide market.

Important: Sales of products are subject to our Terms and Conditions which are available upon request. All specifications, information and photos are a guide only and are subject to change without notice. Please ring to confirm details. Warning: For correct operation of this appliance it is essential to observe manufacturer's instructions.

Warranty

Any claim under this warranty must be made within 6 Years of the date of purchase of the product. This product is warranted to be free of defect of material and workmanship for 6 Years from date of purchase. Warranty is 6 years parts, 1 year parts and labour, excludes cartridge.

To make a claim under the warranty, take the product and proof of purchase to place where you purchased the product, and they will lodge a Warranty Request with Puretec.

Puretec will pay your reasonable, direct expenses of claiming under this warranty. You may submit details and proof of your expense claim to place of purchase for consideration.

The warranty only applies if the product was used and/or installed in accordance with the user guide and/or installation instructions. This warranty is given in lieu of all other express or implied warranties and manufacturer shall in no circumstance be held liable for damages consequential or otherwise or delays caused or faulty manufacturing except as excluded by law.

Applicable to all above, is that the warranties need to be approved by Puretec to ensure product was not incorrectly used, installed or claimed. False and incorrect claims will be pursued at Puretec's discretion, including chargeable inspection and labour costs incurred.

All installation and service work should be completed by qualified tradespeople. Faulty operation due to unqualified persons will result in voided warranty coverage.

Warranty/Australia

This warranty is given by Puretec Pty Ltd, ABN 44 164 806 688, 37-43 Brodie Road, Lonsdale SA 5160, telephone no. 1300 140 140 and email at sales@puretec.com.au.

This warranty is provided in addition to other rights and remedies you have under law: Our goods come with guarantees which cannot be excluded under the Australian Consumer Law. You are entitled to replacement or refund for a major failure and to compensation for other reasonably foreseeable loss or damage. You are also entitled to have the goods repaired or replaced if the goods fail to be of acceptable quality and the failure does not amount to a major failure.

Warranty/New Zealand

This warranty is given by Puretec NZ LP, Reg. No 50081773, PO Box 875 Cambridge 3450 NZ, telephone no. 0800 130 140 and email at sales@puretec.co.nz.

This warranty is provided in addition to other rights and remedies you have under law: Our goods come with guarantees which cannot be excluded under the Consumer Guarantees Act. You are entitled to replacement or refund for a major failure and to compensation for other reasonably foreseeable loss or damage. You are also entitled to have the goods repaired or replaced if the goods fail to be of acceptable quality and the failure does not amount to a major failure.



AUSTRALIA

P 1300 140 140

E sales@puretec.com.au

W puretec.com.au

NEW ZEALAND

P 0800 130 140

E sales@puretec.co.nz

W puretec.co.nz