

The pump is a horizontal multistage surface mounted pressure system pump supplied with a 1.2m Australian power plug and a 2.2 bar cut in automatic restart pressure controller. The pump must be used for flooded suction application. Used especially for supplying water to domestic applications.

Model Number: ASC M55/85
Item Number: 810206

Pump Data

Pressure Rating: 5.5 bar | 550kPa
Min. fluid temp: 4° C
Max. fluid temp: 85° C
Max. operating temperature: 40° C

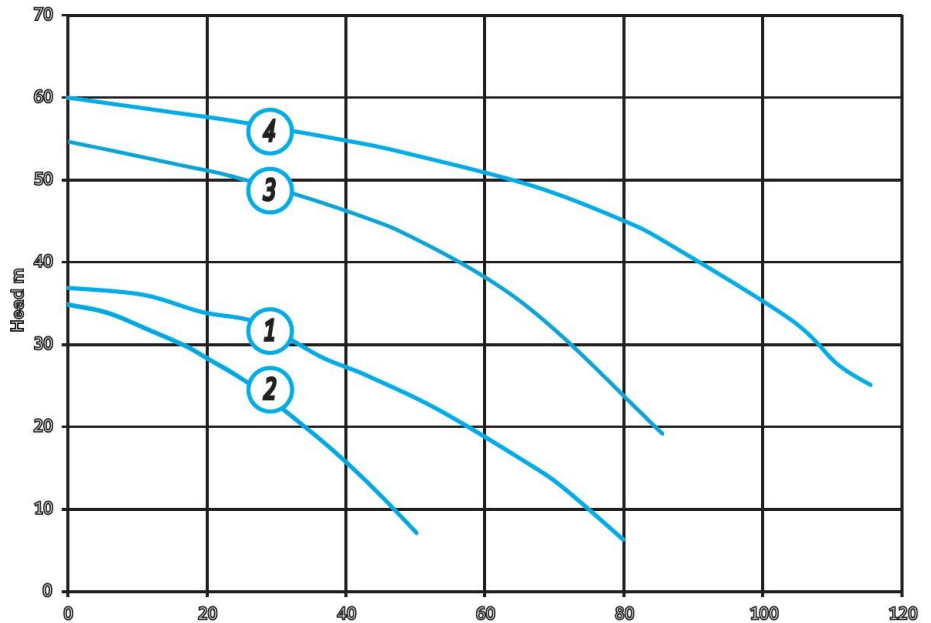

- 1 ASC-M37/80
- 2 ASC-M38/50
- 3 ASC-M55/85
- 4 ASC-M60/120

Max Flow Rate: 85LT/min
Max Head: 55m
Fluid: Water, pure
Density: 998.3 kg/m³

Materials

Pump Body: Stainless Steel
Support: Cast Aluminium
Motor Body: Cast Aluminium
Mechanical Seal: Graphite / Silicon / Carbide
Impeller: Stainless Steel
O Ring: Nitrile
Power Cable: 1.2m H05

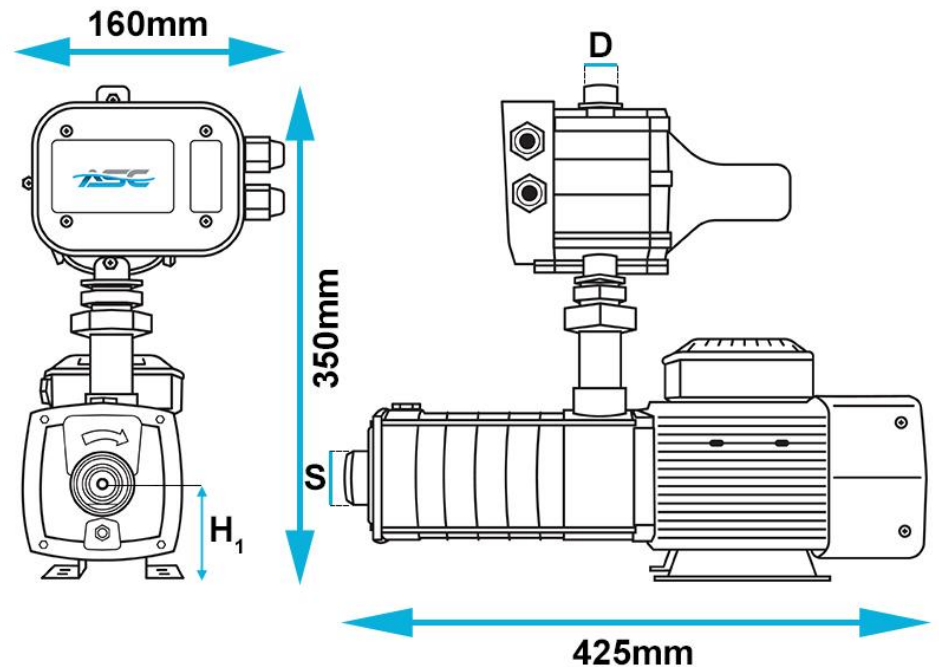

Electrical Data

Phase: Single Phase 1 ϕ
Rated Voltage: 220-230V ~

Dimensions (mm)

A (length)	425mm	S	25mm
B (width)	160mm	D	25mm
H (height)	350mm		
H ₁ (centre)	76mm		

Mains Frequency:	50Hz	Boxed Weight: Pump Weight:	16.0kg
P2 (kW):	750W		15.0kg
HP:	1.0 hp		
Current:	3.125A		
Capacitor:	20μF		
VL:	450V		
Motor Duty:	Continuous		
Motor Type:	Asynchronous		
Ingress Protection:	TEFC		
Insulation Class:	IP 54 Motor		
Motor Protection:	B In-built thermal overload		

ASC Water Tanks reserves the right to make modifications without notice.